

'74 FORD RECREATION VEHICLES

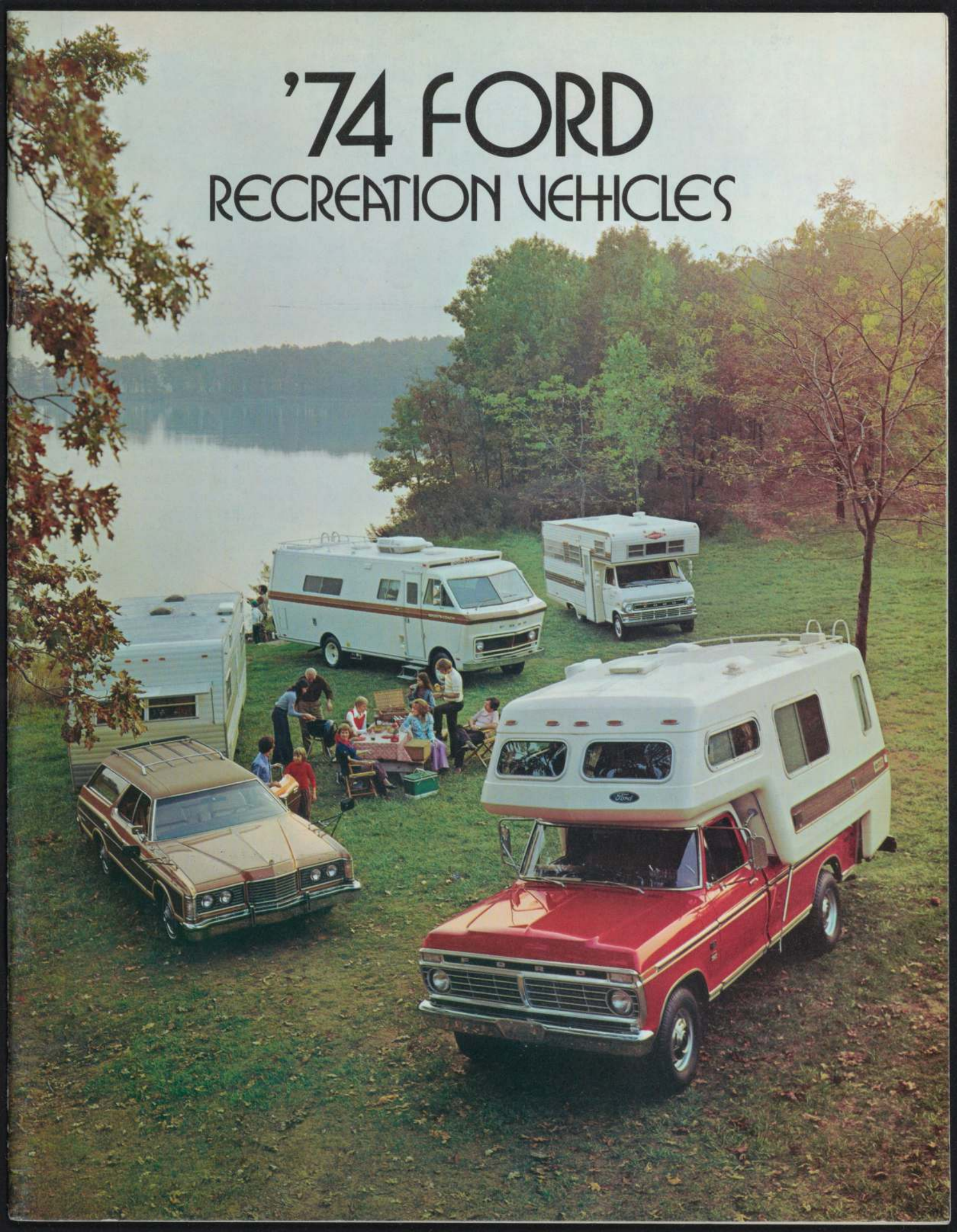

AN INTEREST IN CAMPING THAT SPANS HALF A CENTURY



prised this motorcade included three well-known Americans—Henry Ford, Thomas Edison and Harvey Firestone, with their wives.

Actually, Henry Ford first became interested in the idea of motorized camping some years earlier . . . in 1914, when he and Thomas Edison toured the Florida Everglades together.



The four Vagabonds (left to right) Thomas Edison, Harvey Firestone, John Burroughs and Henry Ford.

That outing led to a series of trips during the years from 1914 to 1920, by a "bachelor" group consisting of Henry Ford, Thomas Edison, Harvey Firestone, and naturalist, John Burroughs. Calling themselves the Vagabonds, they enjoyed roughing it and cheerfully endured rain, cold, black flies and sleepless nights.

But by 1921, their wives had tired of their husbands' bachelor life style and were insisting that they

be included on future trips. Thus began the era of family recreational travel that has now achieved such popularity in the United States.

Once the ladies began taking part in the travel plans, equipment soon included separate 10-foot square tents for sleeping (and, of course, big brass beds) . . . a dining tent twice that large with a 9-foot lazy-susan-type circular table and folding chairs. Also, newfangled gasoline stoves; and plenty of light was insured at every campsite by the presence of Thomas Edison. In fact, Henry Ford built a portable electric generator to light Edison's lamps, which were strung throughout each tent.

Over the years, Henry Ford's interest in motorized camping and its development never diminished. In 1935, for instance, he had a special travel trailer built, for study and evaluation.



Later, this self-contained trailer was given to aviator, Charles Lindbergh, who used it for vacation trips throughout the United States. The Lindbergh trailer and a collection of early Ford camping vehicles are on display in the Henry Ford Museum, Dearborn, Michigan.

Over the years, there have been many other innovations in recreational vehicles from the Ford Motor Company, many stemming from Mr. Ford's interest in motorized camping.

On a sunny afternoon in 1921, an unusual caravan of cars and trucks slowly made its way through the hilly Pennsylvania countryside. There were five vehicles in all, including a Ford Model T touring car with van-type body, containing a water storage tank and kitchen utensils. The other vehicles in the group were equally loaded with all the paraphernalia required for comfortable outdoor living. The hearty outdoorsmen who com-



Pictured here are: Harvey Firestone, Thomas Edison, President Warren Harding, Henry Ford, Edsel Ford, their wives, family members and friends.

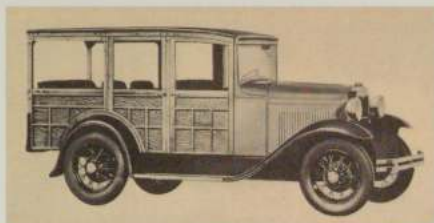

In 1929, the **first production station wagon** built in America, the "woodie," rolled off Ford's assembly lines. More recently, Ford made heavy-duty towing components available on Ford cars in 1961.

Another Ford "first" was introduced in 1965: **Camper Special packages for Ford Pickups**, with special chassis and engine options for safe, trouble-free camping trips.

Car and Truck trailer-towing recommendations were first published in 1969 and **complete towing packages** containing all the essential components needed for trailer towing were offered for cars in 1971.



In 1973, the 140" wheelbase **F-350 Super Camper Special Pickup** appeared—built specifically to carry slide-in campers. 1973 also saw the emergence of a unique fiberglass **Pickup Box Cover**, designed especially for Ford pickups.

You'll see some **new 1974 Ford** innovations in recreational products on the following pages—like Ford's new American Road Camper, an aerodynamically designed 11½' slide-in camper body for pickup trucks, that's filled with better ideas for more carefree camper living.

This brochure is designed to help you select a recreational vehicle that fits your life style, travel plans and budget. Information is provided on towing and special equipment recommendations, facts about proper loading, available options and much more.

Historical photos, courtesy of the Ford Archives, Dearborn, Michigan.

TABLE OF CONTENTS

	Truck Camper Buyer's Guide	4
	Ford's American Road Camper <i>... with better ideas to make camping more fun.</i>	5
	Ford F-350 Super Camper Special <i>Super in every way ... in length ... strength ... comfort ... and convenience.</i>	6-7
	Ford F-250 Camper Special <i>A long-time favorite of America's campers.</i>	8
	Ford F-350 Chassis Mounted Campers and 4-Door Cab Models <i>For added luxury and living space.</i>	9
	Ford F-250/F-350 Camper Special Packages	10
	Ford Pickup Box Cover	11
	Four Wheel Drive—Bronco, F-100 and F-250 <i>To take you where many others dare not go!</i>	12
	Motor Home Buyer's Guide	13
	Club Wagon and Econoline Camper Conversions <i>Room for the great outdoors.</i>	14-15
	Ford Motor Home Chassis <i>The modern motor home chassis.</i>	16-17
	Trailerling Classes	18
	Trailer Buyer's Guide	19
	Pickup Trailer Towing Packages	20-21
	Car Trailer Towing Packages	22
	Tow Vehicle, Trailer and Hitch Recommendations	23
	Recommended Towing Equipment	
	<i>Ford</i>	24
	<i>Torino/Ranchero</i>	25
	<i>Thunderbird</i>	26
	<i>Pinto/Maverick/Mustang II</i>	27
	Car and Truck Options and Accessories	28-29
	Tips for Trouble Free Trips	30
	Weight Factors to Consider	31

PICKUP CAMPERS

VARIETY TO SUIT YOUR OUTDOOR LIVING NEEDS

Whatever your needs, there is a pickup camper designed for your budget, ranging from a suggested retail price of less than \$300 for a pickup box cover to over \$5,000 for a chassis-mounted camper (excluding truck).

Pickup Camper advantages to consider

Camping by truck, rather than by car-and-trailer or motor home, offers several advantages. The

basic ruggedness of the truck construction makes it ideal for off-road travel and getting back into more primitive camping areas.

In most cases, you can **remove** the camper body from the pickup truck allowing you to use the pickup as a second car, for work or pleasure during the week. There is a truck camper to fit both your life style and budget. Let's look at the basic types to consider.



F-100 with Pickup Box Cover



F-250 with cab-over camper without rear overhang



F-350 Super Camper Special with cab-over camper with rear overhang

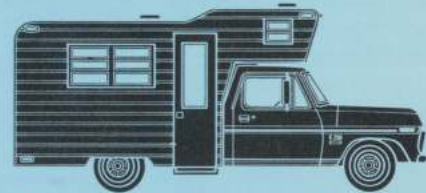

F-350 Chassis Cab with chassis-mounted camper

Slide-in campers

Most slide-in campers can be removed from the truck, and provide a "cab-over" section that contains the main sleeping area. Slide-in camper lengths range from 6 to 8 feet to 12 feet with suggested retail prices that run from about \$1,500 to over \$5,000. Telescoping camper bodies, which can be raised at the campsite, and lowered for travel, are priced from \$1,000 to more than \$3,000.

Chassis-mounted campers

This type of camper bears some similarities to mini-motor homes in that the camper body and truck are an integral unit, almost exclusively designed for recreational purposes. Because the camper body is mounted directly to the pickup frame and not limited by the necessity to fit into a truck box, there is more interior living and storage room available.

Chassis-mounted camper bodies normally range in length from 14 to 15 feet; and most body manufacturers will install walk-throughs between the camper body and the truck cab.*

You may wish to consider a Pickup Box Cover

Like the streamlined fiberglass model Ford offers exclusively—fits over the pickup cargo area and provides basic protection from the elements. It means extra convenience on trips into the backwoods . . . and it's great for protecting your personal gear and tools when you're at home.

Things to look for before buying

Any camper should be large enough to enable your family to sleep and eat in comfort. The sleeping quarters should be adequate for long trips of a week or more. It's wise to compare the length and width of all the beds and convertible bunks with those at home.

Everyone should be able to sit down and eat at the same time. You'll want to be certain to select a large enough kitchen and dining area to handle your family's needs.

Check-out the storage

On-board stowage should be sufficient for extra equipment such as fishing poles, folding chairs,

lanterns, etc. — plus an adequate supply of clothing and food. It's important that you pay special attention to the amount of storage located up near the roof of the camper, since excess weight in this area can influence your pickup's handling characteristics.

Planning on stops in primitive areas?

Consider campers with large holding tanks, heating units, water storage tanks and 12-volt battery-operated accessories. Make sure the bathroom area is comfortably adequate, with an arrangement you prefer.

Choose a floor plan that suits your needs

The best floor plan is the one that places the heaviest components, the fresh water tank and kitchen appliances such as the refrigerator, at the forward end of the camper . . . and distributes most of the weight between the truck's axles. In furnishing your camper coach, consider family size, privacy needs of family members, how much time you'll be spending on your trips, and ease of moving around inside.

*Truck body installations and modifications are the responsibility of the body manufacturer. Owners should assure themselves of the load and handling capabilities of their vehicle when selecting a camper or contemplating custom add-ons or modifications.

FORD'S AMERICAN ROAD CAMPER

...WITH BETTER IDEAS
TO MAKE CAMPING
MORE FUN

Styled . . . engineered . . . and tested by Ford

The American Road Camper's better ideas in exterior design and interior living convenience didn't just happen. They were the direct result of lengthy, in-depth research among camping enthusiasts like yourself . . . and of extensive studies of recreational vehicle usage.

In response to this research, Ford has developed the American Road Camper . . . designed to provide a host of better ideas for more camping fun and easy-living convenience.

Better ideas in basic camper design

Aerodynamically designed to cut air drag and make handling easy. Smooth tapered sides "spill" the wind around the body for good crosswind stability.



Excellent weight distribution is achieved by locating water holding tanks under the floor. These tanks, with baffles to check surging are contained between double decks of exterior plywood. Other heavy elements are positioned for good left to right balance.

Durable fiberglass body has no seams to leak or corrode. This material has been proven for years. Now Ford brings you a one-piece fiberglass camper — strong and watertight.

High-efficiency foam insulates the body shell. Insulation is spray-bonded to the fiberglass.



An interior designed with liveability in mind

Floor plan. Offers an efficient traffic pattern from the outside to the dinette or bathroom without passing through the kitchen.

Large kitchen. Well-planned and equipped with a three-burner LPG stove with oven and hood vent, a modern, innovative, two-way stainless steel sink, plus numerous conveniently located drawers and cabinets and a surprising amount of counter space.

Unusual headroom in the cab-over. Allows an adult to sit up in the center of the bed. The double bed (54" x 74") takes regular size sheets and features a restful 4-inch thick mattress.

Booth-style dinette. At the rear of the camper, provides ample adult-size legroom and features a dinette table which converts into a large 48" x 72" bed.

Plenty of storage space. 12 cabinets with stay-closed latches, a 3 drawer unit, 2 full-size wardrobes.

Attractive interiors. Rich wood-toned paneling and a choice of three color-coordinated interiors—Rust, Gold or Green.

Comfort and convenience options . . . let you personalize your American Road Camper

Because no two camping enthusiasts are alike in their wants and needs . . . a wide variety of options are available for the American Road Camper . . . these are just a few of the optional equipment items available:

- Roof-mounted 10,000 BTU air conditioner.
- Four-burner stove with extra large oven/broiler and convenient see-through door.
- Radiant-type furnace or ducted furnace with blower and wall thermostat.
- Choice of entertainment systems: AM-Radio; AM-FM Stereo Radio; AM-FM Stereo Radio and Tape.

The new American Road Camper is an ideal match for Ford's F-350 Super Camper Special Pickup

FORD F-350 SUPER CAMPER SPECIAL

The 1974 Ford F-350 Super Camper Special is specifically designed and engineered from the ground up to accommodate most of today's big 11 to 12 foot slide-in camper bodies . . . it's a vehicle that provides the kind of dependability, durability and versatility that has made Ford an acknowledged leader in recreational vehicles.

GVW Ratings Up To 10,000 Pounds!

You can carry up to 5115 pounds of payload including the weight of the slide-in camper, passengers, options and camping gear and . . .

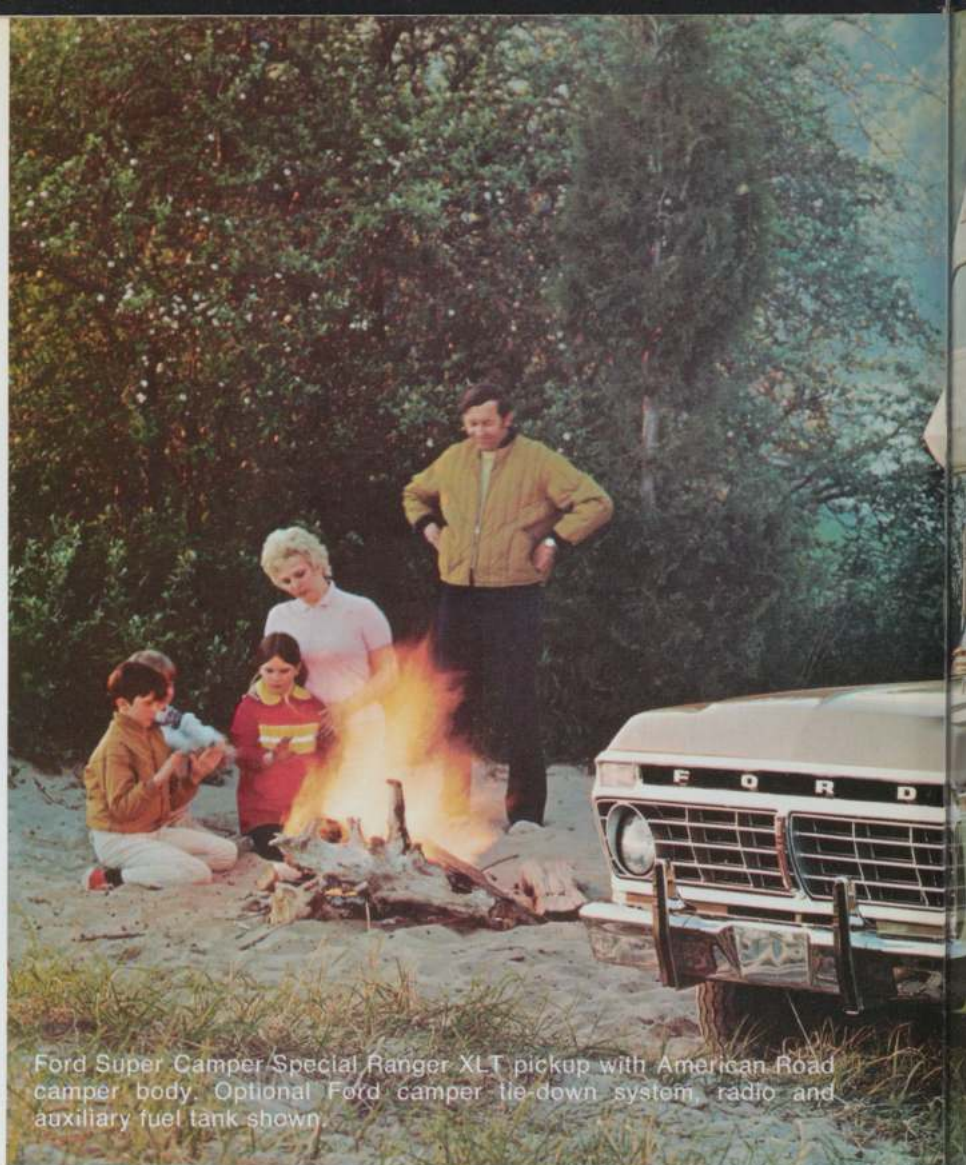

Ford Super Camper Special Ranger XLT pickup with American Road camper body. Optional Ford camper tie-down system, radio and auxiliary fuel tank shown.

6

Super Single Rear Tires . . .

are standard on F-350 Super Camper Special models ordered with the 10,000 lb. GVW package. The extra-wide 12.00 x 16.5 E Super Single Rear tires give you noticeably easier cornering and driving than duals.

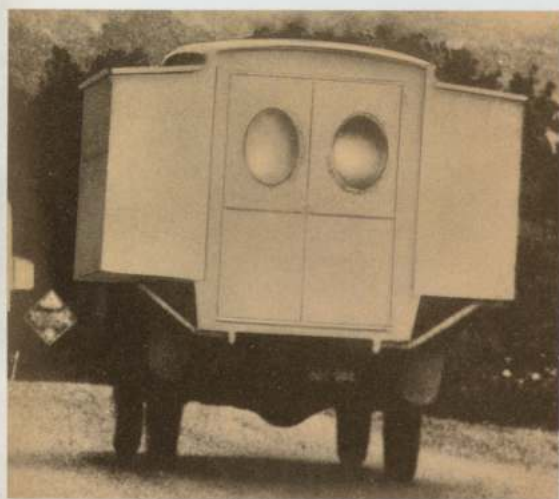

Early slide-in camper, mounted in a 1921 Ford pickup.

SUPER IN EVERY WAY... IN LENGTHS

Optional 460 V-8 Engine

An optional 460 cubic inch engine is available to give you extra torque and power and make traveling in the F-350 Super Camper Special more enjoyable even with maximum loads under the most demanding road conditions. The 460 cubic inch engine comes with a solid-state ignition system for better electrical system reliability than conventional systems . . . there are no points and condenser to ever need adjustment or replacement.



Long 140-inch wheelbase

The 140-inch Super Camper Special wheelbase is the longest ever

offered on a Ford pickup, and allows better weight distribution with the camper body balanced between front and rear axles for stability and easy handling. Standard **front and rear STABILIZER BARS** and the wide 65-inch front tread provide stability for camper carrying.

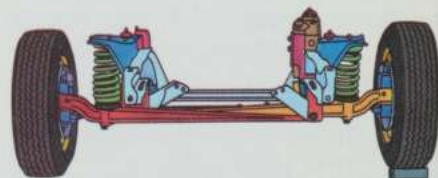

Twin-I-Beam Front Suspension

It's smooth going on rough roads thanks to Ford's famous Twin-I-Beam suspension. Two rugged, forged I-beam axles work with big, individual coil springs to ease each wheel over bumps independently . . . cushioning your cab and camper body from road shocks.



STRENGTH... COMFORT... AND CONVENIENCE

7

Heavy-Duty Frame

A heavy duty frame with extra deep side rails contributes to the F-350 Super Camper Special's great load-carrying ability, and provides long lasting vehicle strength.

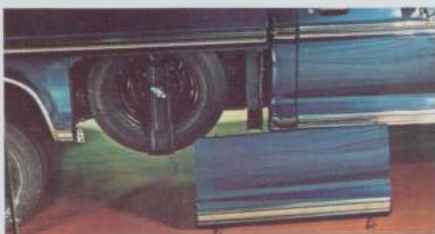

side the cab, behind the axle and between the frame rails, which opens up storage space behind the seat. The optional 22.5 (Calif. 20.2) gallon auxiliary gas tank is similarly frame-mounted. And **both** gas tanks fill on the same side of the pickup. **Easy-to-reach spare tire location**, too. No need to struggle, pulling the spare out from under a low-slung camper body. Simply unfasten a panel on the right side of the pickup box ahead of the rear axle. **Automatic transmission and extra cooling** are standard. Ford's SelectShift Cruise-O-Matic transmission combined with a heavy-duty transmis-

sion oil cooler and extra-cooling radiator, let you drive in confidence in mountainous terrain or in desert-like heat.

Other F-350 Super Camper Special standard features include:

A 360-cubic-inch V-8 engine . . . power front disc brakes . . . 55 amp alternator and 70 amp battery . . . oil pressure and ammeter gauges . . . bright western mirrors . . . heavy-duty shock absorbers . . . dual horns . . . and camper wiring harness (an optional heavy-duty wiring harness with 61 amp alternator is also available).

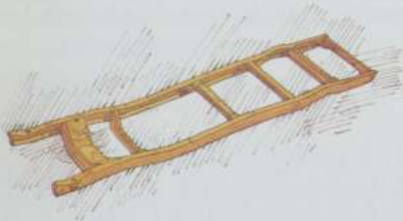

Car-like riding comfort, too!

Deep 7-inch foam-padded seats make travel less tiring. The roomy cab offers a full 66 inches of shoulder room . . . allowing three adults to ride in comfort.

A wealth of convenience features

Including a **gas-tank location out-**



F-250 Ranger XLT Camper Special

THE FORD F-250 CAMPER SPECIAL...

A LONG-TIME FAVORITE OF
AMERICA'S CAMPERS

**Every year more people
are leaving home with
their camper on a Ford
F-250 Pickup**

The F-250's a truck that promises and delivers a lot of extra ruggedness plus comfort and convenience. Here are some of the reasons why the F-250 might well be the way to go . . . with your camper.

Big Load-Carrying Capacity!

The F-250 offers gross vehicle weight (GVW) ratings up to 8,100 lbs. Its 133-inch wheelbase provides good weight distribution for today's popular 8 to 11 foot campers.

Durability

The F-250, like all Ford pickups, is built to take it, even in the roughest backwoods country. It gives you the strength of double-wall steel construction in the hood, pickup box sides and other vital areas. It features strong, welded sheet metal sections in the body for strength and durability . . .

And over 200 square feet of the F-250's sheet metal is zinc coated to protect against rust and give you long years of service.

Car-Like Ride

The exclusive Ford Twin-I-Beam front suspension provides a smooth car-like ride over rough roads, making the F-250 ideal for camper installations. Go where you will and arrive relaxed . . . ready for fun.

Equip it with a Camper Special Package

When you order the F-250 with a Camper Special Package your vehicle is all set for camping. (See page 10 for a full description of the Camper Special Package content.)

A Cab-Full of Better Ideas!

- A spacious car-like cab — with more shoulder room than a standard-size passenger car for comfortable 3-adult seating.
- Solid comfort of a full foam seat — 7-inches deep.
- The gas tank is positioned outside the cab, in a protected location between the frame rails . . . leaving room for a big 5½-foot wide storage space behind the seat.
- Select from three trim levels . . . Custom, Ranger or Luxurious Ranger XLT.
- Choose from a full assortment of car-like options, including air conditioning and AM/FM Stereo radio.

F-350 CHASSIS-MOUNTED CAMPERS AND 4-DOOR CAB MODELS

Chassis-mounted Campers

This chart shows the minimum equipment required for using a chassis-mount camper body with

either a single-rear-wheel or dual-rear-wheel F-350 Chassis-Cab unit. Equipment indicated below does not necessarily represent the maximum equipment available.

MINIMUM CHASSIS REQUIREMENTS

	F-350 CHASSIS CAB WITH CAMPER SPECIAL PACKAGE					
	Single		Dual			
Rear Wheels						
GVW Rating (lbs.)	8000		9000		10,000	
Wheelbase (inches)	137"	161"	137"	161"	137"	161"
Max. Camper Body Length (for reference only)	11 Ft.	12 Ft.	12 Ft.	14 Ft.	12 Ft.	14 Ft.
Engine (minimum)	360 V-8					
Transmission	Cruise-O-Matic or 4-Speed					
Tires (a)						
Tubeless, front/rear	(b) 8.75 x 16.5 E/E		8.00 x 16.5 D/D		8.00 x 16.5 D/E	
Tube-type, front/rear	(b) 7.50 x 16 C/E		7.50 x 16 C/C		7.50 x 16 C/D	
Recommended Axle Ratios:						
w/8.00 x 16.5 & 8.75 x 16.5 tires	3.73					
w/9.50 x 16.5 & 7.50 x 16 tires	4.10 (3.73 w/390/460 Eng.)					

(a) If spare tire is ordered, rear tire size should be ordered.

(b) For optimum handling and stability with full-size camper bodies 9.50 x 16.5 D tubeless tires are recommended with single rear tires F-350 Chassis-Cab units.

For added luxury and living space

A Ford F-350 chassis-cab model (either 2- or 4-door cab) equipped with an optional Camper Special Package, is an excellent vehicle for use in combination with a camper body mounted directly to the frame. Camper bodies up to 14* feet long and 96 inches wide can be installed.

*2-Door Model Only



F-350 with chassis-mount camper

Big 4-door cab available with F-350 chassis-cabs and pickups

The roomy 4-door cab offers additional convenience, with seating space for six in the cab on two comfortable bench seats . . . permitting the entire family to ride up front and enjoy the scenery. The 4-door cab may be equipped with four optional bucket seats, if you wish. This seating arrangement is ideal for chassis-mounted camper applications as it accommodates the installation of a convenient "walk-through" between camper and cab.*

If you're planning to carry a slide-in camper, you might consider meeting your needs with an F-350 4-door cab model equipped with an 8-foot Styleside pickup box and Ford's Camper Special Package. (Refer to page 10.)

The F-350 137" and 161" wheelbase models without a camper special package should be equipped with stabilizer bars if it is to be used to carry a camper.



F-350 4-Door cab pickup with cab-over slide-in camper

*Truck body installations and modifications are the responsibility of the body manufacturer. Owners should assure themselves of the load and handling capabilities of their vehicle when selecting a camper or contemplating custom add-ons or modifications.

F-250/F-350 CAMPER SPECIAL PACKAGES

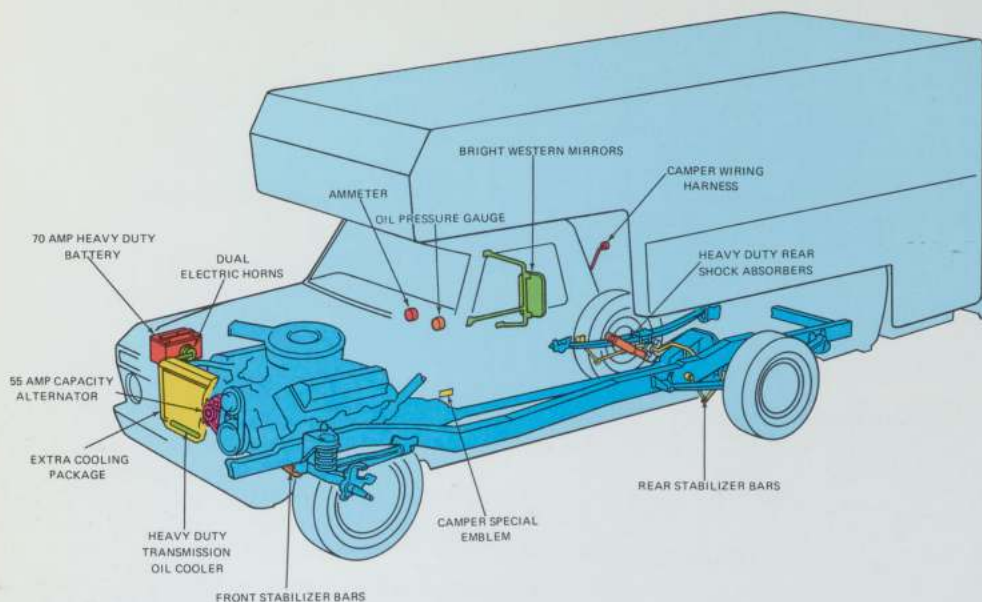

The Camper Special Packages available on pickups consist of equipment specially selected to give you trouble-free performance . . . plus comfort and convenience . . . at an attractive package-price.

The following equipment is included:

Extra Cooling Package. Heavy-duty radiator with large surface area and fan provide for efficient engine cooling at high speeds or in heavy traffic.

Heavy-duty Transmission Oil Cooler on vehicles equipped with

Cruise-O-Matic Transmission—for optimum performance on extended trips in hot weather.

70 Amp-hr. Heavy Duty Battery and 55 Amp. Capacity Alternator.

To accommodate the heavier electrical load caused by extra camper lights and to assure adequate power for nighttime use and quick recharging while under way. Also available is Ford's auxiliary battery option . . . which provides a separate power source for your camper's electrical system. (Both standard and auxiliary batteries recharge while you drive.)

Ammeter. Keeps the driver informed of battery and electrical system condition.

Oil Pressure Gauge. For constant monitoring of the engine lubricating system.

Heavy-Duty Rear Shock Absorbers. Help minimize road bumps and help soak up vibration (Included with F-350 only—with 137" and 161" wheelbase). Optional with F-250, Standard with 140" wheelbase.

Front and Rear Stabilizer Bars. For added stability when carrying high, heavy loads.

Camper Wiring Harness. Provides 12-volt current to the camper body for interior and exterior lights. Each of the seven wiring harness leads is color-coded and tagged for circuit identification. An optional heavy-duty wiring harness (50-amp capacity) which includes a 61-amp alternator is available on selected models.

Dual Bright 6" x 10" Extended Arm Western Mirrors. Project beyond the width of the camper body to provide good visibility on both sides of the vehicle.

Dual Electric Horns produce a loud clear warning signal.

Camper Special Emblem.

MINIMUM EQUIPMENT REQUIREMENTS

The following chart shows the Gross Vehicle Weight Rating and minimum optional equipment required for use with the F-250 Camper Special Package and F-350 Super Camper Special. The equipment shown does not necessarily

represent the maximum equipment obtainable. In many cases, additional equipment is available for maximum camper loads and applications. For example, 9.50 x 16.5 D or E tires are recommended for improved handling and stability on F-250 Camper Special vehicles.

ling and stability on F-250 Camper Special vehicles.

The F-350 Styleside pickup without a camper special package should be equipped with stabilizer bars if it is to be used to carry a slide-in camper.

	F-250 WITH CAMPER SPECIAL PACKAGE			F-350 SUPER CAMPER SPECIAL (WITH STANDARD EQUIPMENT)		
Wheelbase (inches)	133"			140"		
Maximum Camper Body Length (for reference only)	11 Ft.			12 Ft.		
GVW Rating (lbs.)	6900	7500	8100	8350	9000	10,000
Engine (minimum)				360 V-8		
Transmission	Optional Cruise-O-Matic or 4-Speed			Cruise-O-Matic		
Tires (a) Tubeless, front/rear	8.75 x 16.5 E/E (b)	9.50 x 16.5 D/D (c)		8.75 x 16.5 E/E	9.50 x 16.5 D/E	9.50 x 16.5 E 12.00 x 16.5 E(d)
Tube-type, front/rear	7.50 x 16 D/D	7.50 x 16 E/E		7.50 x 16 E/E	—	—
Recommended Axle Ratios: w/8.75 x 16.5 tires w/9.50 x 16.5 & 7.50 x 16 tires	3.73 (3.54 w/390 & 460 V-8) 3.73			4.10 (3.73 w/390 4V or 460) 4.10		

(a) If spare tire is ordered, rear tire size should be ordered. (Except for 12.00 x 16.5 E)
 (b) For optimum handling and stability with full-size camper bodies, 9.50 x 16.5 D or E tubeless tires are recommended.
 (c) For optimum handling and stability with full-size camper bodies, 9.50 x 16.5 E tubeless tires are recommended.
 (d) Super Single rear tires.



F-100 Ranger XLT with optional Ford Deluxe Box Cover, protection group, wheel covers, white sidewall tires and western-type mirrors.

DESIGNED FOR VERSATILITY

FORD'S EXCLUSIVE PICKUP BOX COVER

Ford engineers designed and styled this handsome and versatile box cover specifically for 1974 Ford F-100, F-250 and F-350 pickups equipped with an 8-ft. Styleside box. It meets both recreational and commercial needs of pickup owners by providing ample lockable space for carrying camping and boating gear as well as tools.

The box cover can also serve as economical sleeping space or shelter from bad weather for sportsmen at the campsite. The extra storage space and convenience provided by Ford's Pickup Box Cover also makes it ideal for pickup owners who tow boats or trailers.

The Ford box cover is styled to complement the lines of Ford Pickups, and is five inches higher than the pickup cab. The box cover comes in two trim levels—standard and deluxe.

Safety Recommendation

Ford Motor Co. recommends that passengers be carried only in the cab of the truck—the area enclosed by this cover should not be occupied unless the vehicle is stationary and the engine is off.



Standard Pickup Box Cover Features

- Durable, lightweight, corrosion-free fiberglass construction
- Tinted glass side and rear windows
- Durable T-handle locking rear liftgate
- Easy operating, rubber cushioned tie-downs to help minimize box cover vibration

- Painted interior
- Light 250 lb. weight for easy removal and installation.
- Adjustable roof vent

Deluxe Pickup Box Cover Features

(In Addition to or in Place of Standard Box Cover Features)

- Sliding side windows with screens
- Bright side and rear window moldings
- Interior dome light
- Color-keyed exterior accent stripe in choice of 5-colors—trims front and lower edges of box cover

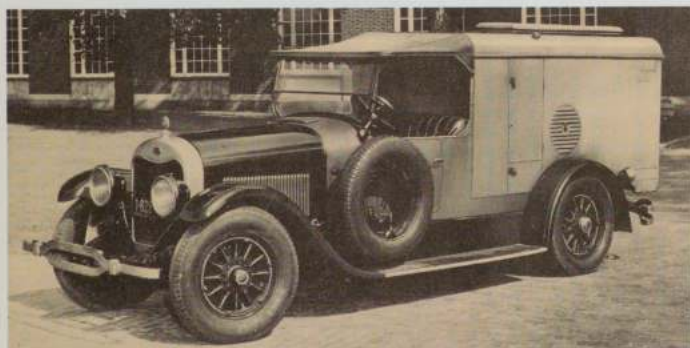

1922 Lincoln Refrigerator Truck, used on early camping trips by Henry Ford.

Candyapple Red, Light Grabber Blue, Limestone Green Metallic and Sequoia Brown Metallic accent colors are available with matching Ford pickup truck colors. Wimbledon white stripe available with all other Ford pickup exterior colors.

FOUR-WHEEL DRIVE ...

TO TAKE YOU
WHERE MANY OTHERS
DARE NOT GO!

BRONCO

For back country exploration, to search out unspoiled wilderness vistas, or to take the entire family plus all the recreation and camping gear needed to spend several days in off-the-beaten path places, you need the four-wheel drive flexibility of Bronco. With a 33.5 ft. turning circle, Bronco maneuvers easily through tight spots.

Bronco's standard free-running hubs reduce drag and minimize wear. Its high ground clearance and "almost identical track" front and rear axles, plus its 4-wheel drive traction, all combine to carry you comfortably across the roughest terrain. Bronco can tow trailers up to 2,000 pounds.

And Bronco's compact size and maneuverability make it an ideal second car . . . perfect for shopping or running errands.



Bronco with Optional Ranger Trim Package

Options that add to Bronco's second car versatility.

Select-Shift Cruise-O-Matic Transmission Option. Available with Bronco's 302-cu. inch V-8 engine provides a choice of automatic or manual shifting for added driving ease.

Power Steering Option available with the 302-cu. inch V-8 provides quick steering response and easy handling, even in rough off-road situations.

tough travel including: 360 V-8 engine, heavy-duty front and rear shock absorbers, auxiliary rear springs*, 3550-lb. front axle*, 70 amp-hr battery, 55 amp alternator, traction-lok rear axle.

*F-250 4x4 Only

And for '74 you can get optional **full-time 4-wheel drive** for sure-footed, deep biting traction wherever you are, on the road or off . . . you can select high or low range as you need it, with a convenient shift lever in the cab.

F-100/F-250 PICKUPS

Ford pickup trucks are also available with the "go-anywhere" traction of optional 4-wheel drive. The F-100 and F-250 4 x 4 pickups will haul small boats, motorcycles, snowmobiles—any equipment or gear—into the off-road wilderness or back country. Ford four-wheel drive pickups give you what you need for rough going: high ground clearance to keep you moving; easy maneuvering with Cruise-O-Matic transmission and power-assist steering options.

Plus the availability of many other optional components built for

Trailer Towing Recommendations for Bronco

Trailer Class (SAE)	Class I (b)
Trailer Weight (lbs.)	Up to 2000 (a)
Tongue Load (lbs.)	10-15% of Gross Trailer Weight (Max. 200 lbs.)
Hitch Type	Weight Carrying
GVW Package	4500 lb.
Engine	302 V-8
Steering	Power
Tires	G78-15 D or equivalent
Transmission	Cruise-O-Matic
Other Equipment	Extra cooling radiator

(a) Maximum GCW (Gross Combined Weight) not to exceed 7000 lbs. GCW equals combined weight of towing vehicle including passengers and cargo plus the weight of the trailer. The GCW and both the front and rear GAWR's must not be exceeded.

(b) For trailers of not more than 25 sq. ft. frontal area.



F-250 Custom with 133 w.b. and optional 4-wheel drive and western-type mirrors

Available in three distinct configurations and price ranges, motor homes are designed for RV buyers who want an integrated vehicle that combines self-contained living features with a truck chassis . . . and allows everyone in the family to travel together under one roof.

MOTOR HOMES:

LUXURY ON THE ROAD AND AT THE CAMPSITE

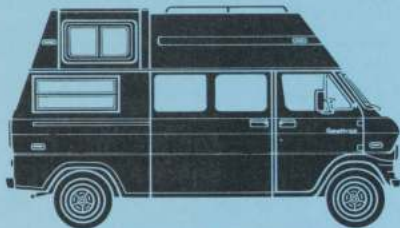

Ford Van conversion



Ford Van mini-motor home conversion



Mid-size motorhome on Ford Chassis



Motorhome on Ford Chassis

Van Conversion: camper or second car

Van conversions make excellent camping vehicles for weekends and vacations . . . and provide economical second-car transportation during the week.

- **Inexpensive to own.** A van conversion is a compact van that has been modified by the addition of equipment such as stove, table, etc., and structural extras like a permanently fixed or manually operated expandable roof to enlarge the interior living area. Suggested retail prices range from as little as \$4,000, up to \$7,000, with maximum conversion and self-containment equipment.

Mini-Motor Homes

Mini-motor homes offer most of the livability features of the larger, more expensive motor homes, but at a cost that's commensurate with their smaller size.

- **More spacious than van conversions.** A large double bed over the cab adds valuable sleeping space, while an extended rear overhang provides more room for closets, bathroom with

shower, and larger kitchen and cupboards.

- **Three basic floor plans are available.** Rear dinette; side dinette; folding table with no formal dining area. The floor plan of the unit you are considering should be evaluated relative to your family size and anticipated travel plans, for maximum enjoyment.
- **Moderately priced for all that you get.** Mini-motor homes offer limited second car flexibility, but they can provide year-round camping with the capability of towing a small boat, trailbike or snowmobile. You can expect to pay from \$7,000 to \$10,000 for one of these units.

Motor homes: the ultimate in recreational vehicle living

Motor homes are big — generally 17 to 28 feet long—and consist of a spacious coach that's built by motor home manufacturers to ride on a sturdy chassis, such as the Ford M-450 or M-500 chassis. In price and level of luxury, these vehicles fall into three major categories:

- **Low priced—with suggested retail prices from \$6,000 to \$10,000.**

17 to 25 feet long, 7 to 8 feet wide, 9 to 11 feet high. No frills, but plenty of sleeping and storage space at minimum cost. Water-holding-LP tankage is usually minimal. These units are designed to introduce you to Motor home living at a relatively inexpensive cost.

- **Moderately priced — with suggested retail prices from \$11,000 to \$15,000.** Averaging 25 feet in length, they sleep four comfortably, and can sleep up to eight. In this popular category, you get a wider choice of equipment, features, construction and floor plans. The wide range of options includes auxiliary power generator, multiple air conditioners and choice of twin or queen size beds.

- **Highest priced—with suggested retail prices from \$16,000 to over \$30,000.** The most luxurious Motor homes for people who intend to spend a lot of time traveling. Many optional features are available: air conditioners, power generators, plush decors and microwave ovens.

Truck body installations and modifications are the responsibility of the body manufacturer. Owners should assure themselves of the load and handling capabilities of their vehicle when selecting a camper or contemplating custom add-ons or modifications.



Econoline Camper Special Mini-Motor Home

14

FORD CLUB WAGONS

ROOM FOR THE GREAT OUTDOORS



1922 Vintage Mini-Motor Home.



Chateau Club Wagon

If you're looking for an economical recreation vehicle that's also an excellent second car, consider the Ford Club Wagon. Available in two wheelbase models, 105½" and 123½", there is more than enough room to take the entire family plus all your camping equipment to your favorite campground.

The 123½" wheelbase model offers maximum flexibility . . . letting you seat up to 12 people comfortably, or with the seats removed carry a small mountain of recrea-

tional gear. With the 5-passenger seating arrangement, the 123½" wheelbase model provides twice the carrying-capacity of a conventional station wagon. And with the Ford Club Wagon you have your choice of either sliding or hinged side door . . . at no extra cost.

The smooth-riding but rugged Twin-I-Beam Front Suspension is also standard . . . as is the unitized body construction, designed to take the hard usage of off-road exploring.

ECONOLINE CAMPER SPECIAL

...A SOLID FOUNDATION FOR MODERN CAMPER CONVERSIONS

Ford Econoline Camper Specials are available with dual rear wheels for good stability when combined with camper bodies up to 13 feet in length. The Camper Special chassis-cab (floor and front end section only) allows the convenient, installation of the camper body of your choice*.

Standard features include: Twin-I-Beam front suspension • 302 V-8, Cruise-O-Matic transmission • power steering • power brakes • 23-gallon fuel tank (Calif. 20.3) • heavy duty shock absorbers and heavy duty components for a 8300 lb. GVW.

Trailer Towing Recommendations for Econoline Van/Club Wagon

Trailer Class (SAE)	CLASS I	CLASS II
Trailer Weight (lbs.)	Up to 2000	2000-3500 (b)
Tongue Load (lbs.) (a)	10-15% of GROSS TRAILER WEIGHT	
Hitch Type	Weight carrying (a)	Weight Distributing (Load Equalizing)
Engine (minimum)	Std.	302 V-8
Cooling Package	Extra Cooling	
Transmission	Std.	Cruise-O-Matic
Trans. Oil Cooler	Not Required	Rotunda C9AZ-7K177-A (Accessory)
Brakes	Std. Drum-type	Power Drum-type
Tires	Std.	G78-15 D or equivalent w/E-200 Vans or Club Wagons
Rear Axle Ratio	Std.	3.50 to 1 w/E-200 Vans & Club Wagons 4.10 to 1 w/E-300 Vans & Club Wagons

(a) Weight carrying hitch, Class I trailer tongue load weight must not exceed 200 lbs.

(b) Maximum GCW (Gross Combined Weight) not to exceed 10,000 lbs. GCW equals combined weight of towing vehicle including passengers and cargo plus the weight of the trailer. The GCW and both the Front and Rear GAWR's must not be exceeded.



ECONOLINE VAN OR CLUB WAGON CONVERSIONS

Tailor-made for more camping enjoyment

You can tailor a Ford Econoline Van or Club Wagon to meet your own individual recreational needs with one of the various types of camping conversions which are available from a number of well-known manufacturers. The extra strength and built-in durability features of these Ford vehicles make them ideal for camping conversions*.

Enjoy all the outstanding features of the Econoline Van or Club Wagon and have the comfort and convenience of a complete camper. This versatile vehicle can serve as your home-away-from-home during vacation time and still fill the needs of a family for a second vehicle for the balance of the year.



Econoline E-200 window van with camper conversion

*Truck body installations and modifications are the responsibility of the body manufacturer. Owners should assure themselves of the load and handling capabilities of their vehicle when selecting a camper or contemplating custom add-ons or modifications.

FORD MOTOR HOME CHASSIS...

THE MODERN MOTOR HOME CHASSIS

Ford M-Series chassis are specifically designed to accommodate today's modern motor home bodies and contain many features specifically requested by motor home owners and manufacturers.

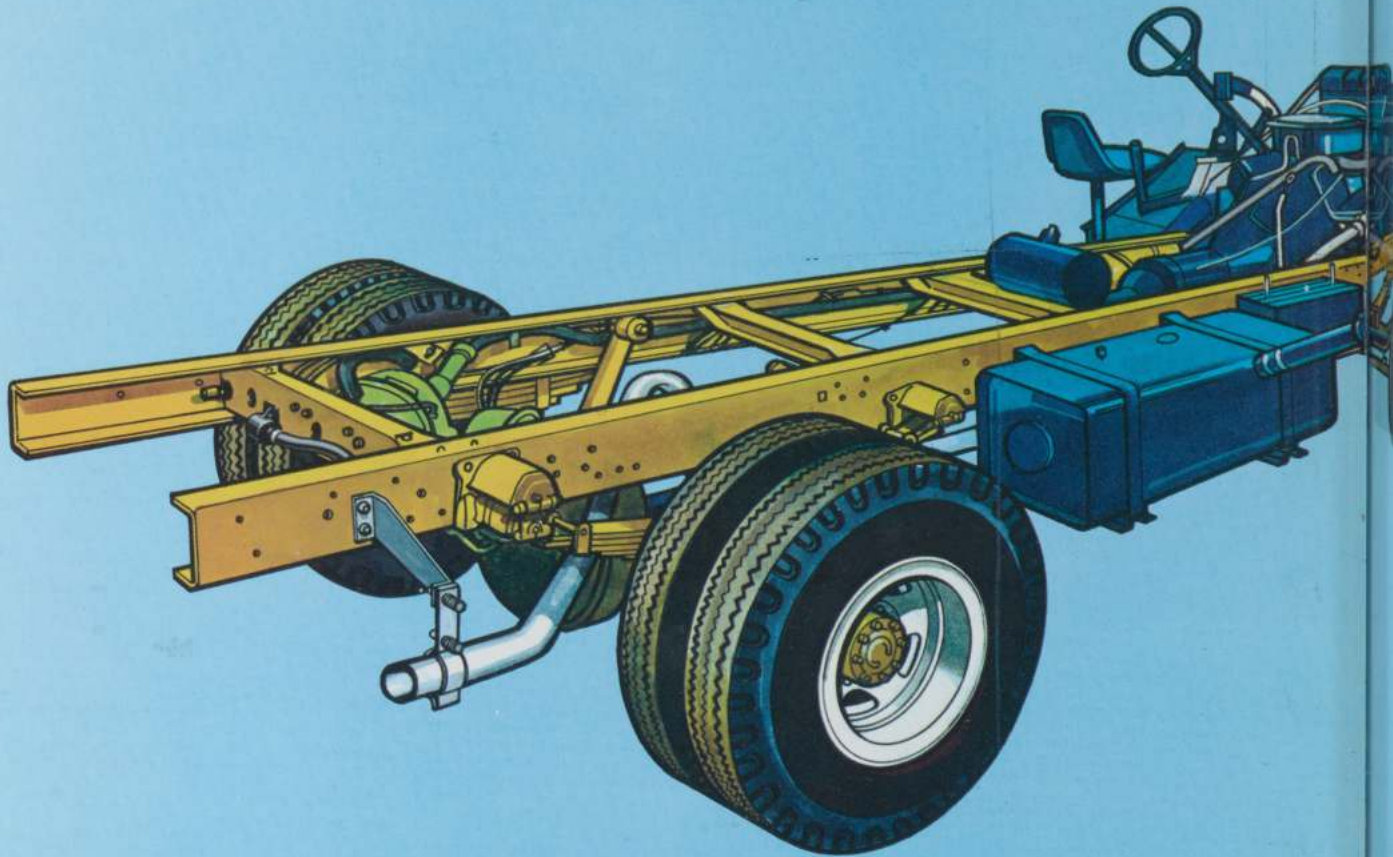

16

Ford's ready to meet your service needs

Ford has a nationwide network of dealers that are available to meet the service needs of motor homes built on Ford chassis. Wherever a motor home owner goes, he isn't far from a Ford dealer. And with Ford's Computerized Parts System, if the dealer doesn't happen to have a particular part, he can obtain it quickly from one of 20 strategically located parts depots.

Wide choice of wheelbases ... to suit a wide variety of motor homes

Ford M-450 chassis, with wheelbases from 125 inches to 158.5 inches, can carry motor home bodies from 18 to 26 feet in length. The M-500 chassis, with wheel-

bases up to 178 inches, can accommodate a motor home body as long as 28 feet. (GVW ratings of Ford chassis range from 12,500 to 15,000 pounds.)

Durable frame provides a solid foundation for dependable performance

An extra-rugged parallel-frame utilizing rigid ladder-type cross members provides an excellent foundation for the motor home manufacturer. The low center of gravity of Ford chassis adds to motor home stability.

Wide-track front suspension

A wide 75.2 inch front track, along with a 5500 pound front axle, helps assure excellent motor home stability and maneuverability.

Progressive Rear Leaf Springs

The heavy-duty rear leaf springs are a new lower rate design, for a smooth, stable ride. These progressive springs adapt automatically as the load changes, and the rear suspension on the Ford motor home chassis features a 13,000 pound capacity rear axle.

Aluminized Exhaust System

The exhaust system is fully aluminized to resist weather and road chemicals and is designed to minimize heat transfer to the interior of the motor home enclosure.

Big Ford V-8 power, standard, for dependable motor home travel

360 V-8 is standard in M-450

Truck body installations and modifications are the responsibility of the body manufacturer. Owners should assure themselves of the load and handling capabilities of their vehicle when selecting a camper or contemplating custom add-ons or modifications.



Motor Home, 1920's style, mounted on a Ford Truck Chassis.



Scout



Sportscoach



El Dorado



Brougham

models; 390 V-8 is standard in M-500 (optional in M-450). Both engines are designed to run on non leaded, low lead or regular gasoline with research octane ratings of 91 or more when the engine is adjusted to factory recommended specifications and are capable of efficiently handling the largest motor home bodies at turnpike speeds.

Additional Standard Features that Add to Motor Home Enjoyment

Like power brakes. They include dual frame-mounted vacuum boosters and a vacuum reserve tank. Also standard, is power steering and Ford's Select-Shift Cruise-O-Matic transmission providing the choice of fully automatic or manual shifting.



Champion



Open Road

FOUR TRAILERING CLASSES...



FOR TOWING WITH TRUCK OR CAR!

18

Total loaded weight determines the class of a specific trailer. This along with the tongue weight and the frontal area of the trailer you own or plan to purchase provide you with a starting point in selecting the right tow vehicle.

Total loaded weight (or gross trailer weight) includes the weight of the trailer and all its equipment, clothing and camping gear.

One of the purposes of the following section of this brochure is to help you select the right vehicle and the right equipment to meet your trailering requirements.

To select the right equipment, and to insure compatibility of tow vehicle and trailer, check the required component specifications for the particular Ford car or truck you are considering as your tow vehicle.

Ford offers Trailering Special Packages for most passenger car and truck models. These packages contain all the special equipment needed for trouble-free towing at a much lower cost than if they were purchased separately.



CLASS I: Light Duty—Under 2000 Pounds Gross Trailer Weight/up to 200 Pounds of Tongue Weight

Tent trailers, and trailers for snowmobiles, motorcycles and light boats are included in this class. Class I trailers can be towed by all Ford vehicles including the Pinto and Mustang II which can tow up to 1000 pounds—when equipped as recommended on page 27.



CLASS II: Medium Duty—2000 to 3500 Pounds Gross Trailer Weight/Tongue Weight—10-15% of the Gross Trailer Weight

Trailers in this class include medium length (up to 18 feet) travel trailers and trailers for larger boats. Ford, Torino, Rancho, Thunderbird and all Ford pickup trucks and vans are ideal vehicles for Class II towing when equipped as recommended on these pages: Cars—pages 24 to 26; pickups—page 20; vans—page 15.



CLASS III: Heavy Duty—3500 to 6000 pounds of Gross Trailer Weight/Tongue Weight—10-15% of the Gross Trailer Weight

This class normally includes large, dual-axle travel trailers. A Ford, Torino, Rancho, Thunderbird and all Ford pickups equipped with a Class III trailer towing package and the equipment recommended on pages 20 and 24 to 26 can readily accommodate the towing requirements for Class III trailers.



CLASS IV: Extra Heavy Duty—6000 to 10,000 Pounds Gross Trailer Weight/Tongue Weight—10-15% of the Gross Trailer Weight

Trailers in this class include the largest and heaviest trailers built for recreation with maximum sleeping accommodations and convenience features. A Ford F-350 styleside pickup with recommended equipment provides ample towing capability for trailers up to 10,000 pounds and fifth wheel trailers to 8,500 pounds. See pages 21 and 24 for extra heavy duty towing requirements. (Ford cars and F-250 pickups can tow up to 7,000 lbs., when properly equipped.)

For the past three decades, more Americans have taken to the road with trailers than with any other type of recreational vehicle. And there are several good reasons why. For instance, there's the convenience of being able to set up camp, and then use your tow vehicle to go sightseeing. Fur-

thermore, trailers can be used in all kinds of weather, and come in a wide selection of sizes, types and price ranges to suit a wide variety of budgets and travel requirements. Generally, trailers provide the most living space for the money, compared to other types of recreational vehicles.

TRAILERS...

AMERICA'S FAVORITE RECREATION VEHICLE



Camping Trailer

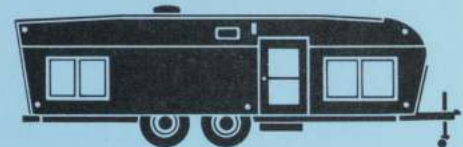

Telescoping Trailer



Conventional dual axle Travel Trailer

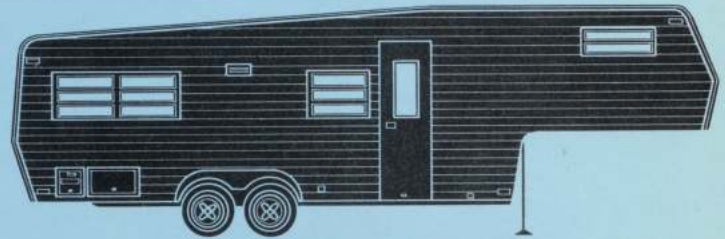

Fifth-wheel Trailer

The basic types of trailers

Folding camping trailers. This type of trailer is ideal for the family moving up from camping in a tent, because the accessories they already own—ice chest, portable stove, sleeping bags, etc.—can still be used. A folding tent-type camping trailer can be purchased for as little as \$600. Or you can pay as much as \$2500 for more elaborate models with complete self-containment features.

Folding trailer sizes range from 8 feet to 12 feet; with weights varying from 300 pounds to 2000 pounds. Low-cost camping trailers have canvas tops, while the more expensive units feature hard tops, constructed of plastic, fiber glass or a combination of aluminum and plastic foam.

Telescoping trailers. They offer many of the features and advantages of the folding trailer and the travel trailer. The upper section can be lowered for towing, which minimizes wind resistance by reducing frontal area by as much as 40%. These units vary in length

from 16 feet to 24 feet . . . with suggested retail prices that range from \$3000 to \$5000.

Travel trailers. Though they're heavier and more difficult to tow than folding camping trailers, they offer many advantages: solid construction that permits greater overall use of insulation materials, enabling them to be used all year long, less time needed to set-up or break camp, more stowage space, and beds that do not require conversion to another use. Generally, travel trailers come in lengths ranging between 12 feet and 30 feet and range in suggested retail price from \$2,000 to more than \$15,000.

Fifth-wheel trailers. A relatively new way to travel that's gaining more attention every year. The fifth-wheel trailer, designed to be towed by a hitch located in the cargo box of a pickup truck, are available in lengths from 18 to 35 feet . . . and at suggested retail prices from \$3,500 to \$10,000 or more. They can be equipped with all the comfort and convenience

features available with conventional travel trailers.

Select a trailer that meets your needs

When you've decided on the basic type, look for quality. Note, in particular, the way the interior trim fits and the assembly of interior woodwork. Usually, the visible quality of the interior gives a good indication of the trailer's overall quality.

Look for livability. Make sure the trailer interior provides adequate privacy for family members; folding doors and privacy curtains are good features to have in your unit.

Pay special attention to the kitchen. Consider the convenience features available for the person who will be doing the cooking. The size and quality of the appliances is particularly important . . . especially the size of the range.

The floor plan of any trailer can be ordered to suit your life style. If you plan to do a lot of campground entertaining, you can select a model with extra couches rather than a unit with permanent bunks.

PICKUP TRAILER TOWING PACKAGES...

INCREASE YOUR TOWING POWER!

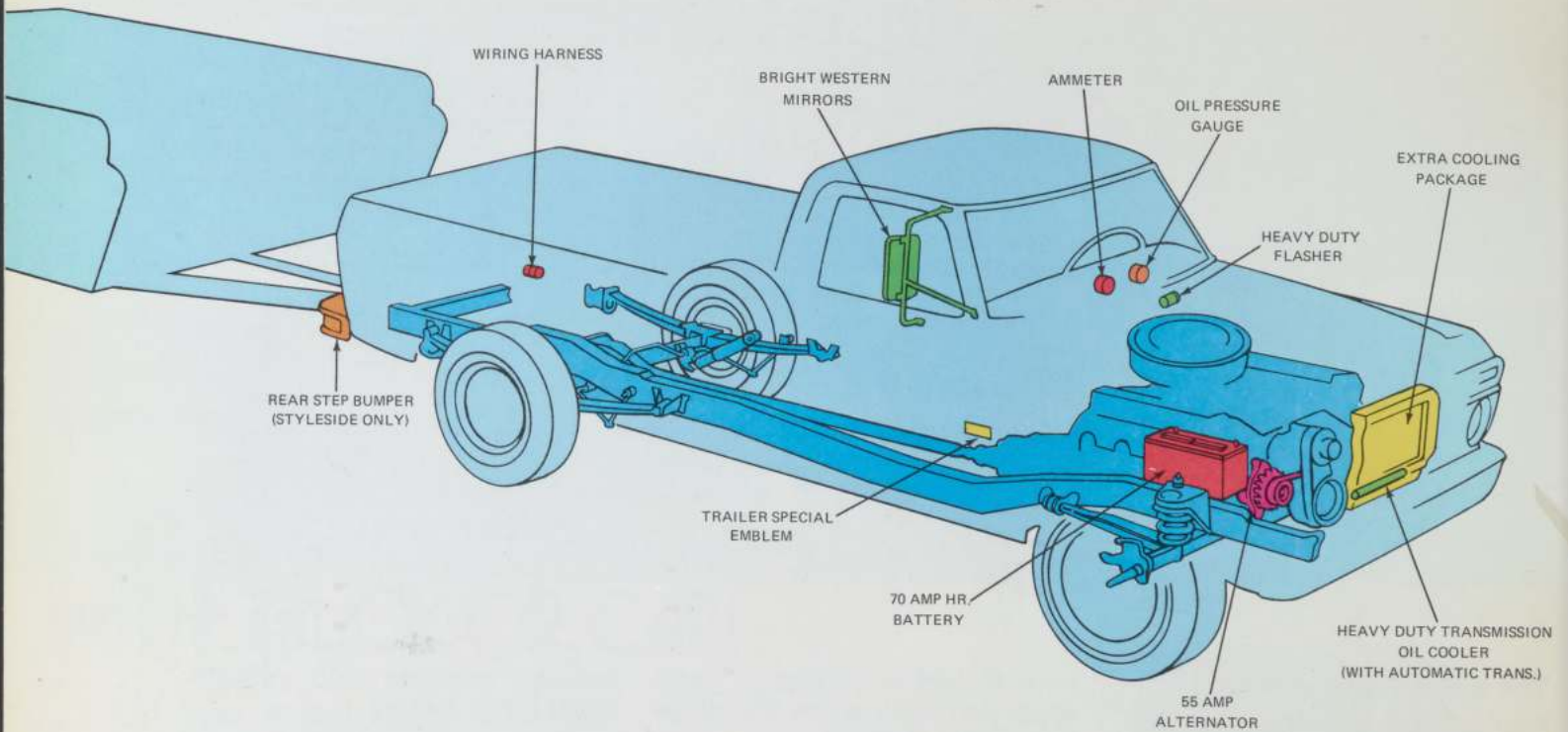

20

Ford provides all the essential heavy-duty components you need for trailer towing with a pickup in two convenient and easy-to-order option packages.

With proper equipment, an F-350 pickup can tow trailers weighing up to 10,000 pounds. The F-350 2-door cab is also an ideal tow vehicle for the popular fifth-wheel type of travel trailers (8,500 lb. max.).

Light Duty Towing Package

F-100, F-250, F-350, 2-wheel drive pickup trucks (For trailers up to 2,000 pounds)

Includes:

- Extra Cooling Package
- Wiring Harness
- Heavy Duty Flasher
- Rear Step Bumper (for styleside models)
- "Trailer Special" emblem

Heavy Duty Trailer Towing Package

F-100, F-250, F-350, 2-wheel drive pickup trucks (for trailers from 2,000 to 10,000 pounds)

Includes:

- Extra Cooling Package
- Wiring Harness
- Heavy Duty Flasher
- Heavy Duty Transmission Oil Cooler (with auto. trans.)
- 70 amp-hr battery (80 amp with 460 engine)
- 55 amp alternator
- Bright Metal Western Long-Arm Mirrors
- Ammeter and Oil Pressure Gauges
- "Trailer Special" Emblem

Ford pickups ideal for towing 5th-wheel trailers

Since their recent arrival on the recreation vehicle scene, 5th-wheel travel trailers have become the fastest growing segment of the travel trailer market. Both the Ford F-250 and F-350 pickups are ideally suited to tow 5th-wheel trailers when equipped as recommended in the charts on page 21.

The 5th-wheel coupling is available from a number of manufacturers and instructions for its installation are the responsibility of the hitch manufacturer or installer.

The hitch load should be approximately 25% of the gross trailer weight. The gross trailer weight (weight of the empty trailer plus whatever payload it will be carrying) should not exceed either the trailer manufacturer's maximum weight ratings or the GVW rating of the pickup used as the tow vehicle. See charts on page 21.

F-100/F-250 MINIMUM TRAILER TOWING RECOMMENDATIONS

Trailer Class (SAE)	CONVENTIONAL TRAVEL TRAILER					FIFTH WHEEL	
	F-100 (4x2)		F-250 (4x2) (f)			F-250 (4x2)	
	I	II, III & IV	I	II & III	IV	II & III	IV
Trailer Towing Package	Light (h)	Heavy	Light (h)	Heavy	Heavy	Heavy	
Trailer Weight (lbs.)	Up to 2000	2000-6000 (a)	Up to 2000	2000-5000	5000-7000 (b)	Up to 5000	5000-6500 (b)
Tongue Load (lb.) (j)	10-15% of Gross Trailer Weight					Approx. 25% GTW	
Hitch Type	Weight (i) Carrying	Weight Dist. (g) (Load Equalizing)	Weight (i) Carrying	Weight Distributing (g) (Load Equalizing)		Frame Mounted	
Gross Vehicle Weight Package (Includes: front and rear springs, tires, brakes and front axle (min.))	5000 lb.	5500 lb.	6200 lb.	6200 lb.	7500 lb.	6200 lb.	7500 lb.
Engine (minimum)	360 V-8						
Transmission	Cruise-O-Matic						
Axle Ratio (minimum)	3.00 to 1	3.50 to 1 (c)	3.73 to 1	3.73 to 1	4:10 to 1 (d)	4:10 to 1 (d)	
Cooling Options (e)	—		(k) (l)		(k) (l)		(k) (l)

(a) Maximum GCW (gross combined vehicle/trailer weight) not to exceed 11,000 lb. GCW equals combined weight of towing vehicle including passengers and cargo plus the weight of the trailer. The GCW and both the front and rear GAWR's must not be exceeded.

(b) Maximum GCW (gross combined vehicle/trailer weight) not to exceed 13,000 lb. (5th wheel 12,500 lb.). GCW and both front and rear GAWR's must not be exceeded.

(c) 3.25 axle ratio w/460 engine recommended.

(d) 3.73 axle ratio w/460 engine recommended.

(e) Recommended for high ambient temperatures.

(f) Camper Special package with automatic transmission may be used in place of trailer towing package providing a conventional load-carrying or equalizer-type hitch is used (no extended hitches).

(g) Hitch sway control recommended for trailers over 3500 lbs.

(h) H.D. towing package is recommended with trailers of over 25 sq. ft. frontal area.

(i) Tongue load not to exceed 200 lbs. with Class I trailer equipped with weight carrying hitch.

(j) Tongue load not to exceed 800 lbs. with Class IV trailer on F-100.

(k) Auxiliary Transmission Oil Cooler (external) std. w/460 engine. Recommended with Classes III and IV.

(l) Super Cooling Package.

F-350 MINIMUM TRAILER TOWING RECOMMENDATIONS

Trailer Class (SAE)	CONVENTIONAL TRAVEL TRAILER			FIFTH WHEEL
	F-350 (140" w.b.)			F-350 (140" w.b.)
	I	II & III	IV	II, III & IV
Trailer Towing Package (a)	Light (g)		Heavy	
Trailer Weight (lbs.)	Up to 2000	2000-5000	5000-10,000 (b)	Up to 8500 (b)
Tongue Load (lbs.) (c)	10-15% of Gross Trailer Weight			Approx. 25% of Trailer Weight
Hitch Type	Weight Carrying (c)	Weight Distributing (Load Equalizing)		Frame-Mounted
Engine (minimum)	360 V-8		390 V-8	
Transmission	Cruise-O-Matic			
Axle Ratio (minimum)	Std.		4.10 to 1	
Cooling Options (d)	—		(e) (f)	

(a) Super Camper Special may utilize its own standard camper package for trailer towing, providing a conventional load-carrying hitch or equalizer-type hitch is used (no extended hitches).

(b) Maximum GVW (gross combined vehicle/trailer weight) not to exceed 16,500 lbs. with 390 engine and 18,500 with 460 engine (5th wheel 15,000 lb.). GCW and both front and rear GAWR's must not be exceeded.

(c) Weight carrying hitch, Class I must not exceed 200 lbs. Conventional hitch sway control recommended for trailers over 3500 lbs. Max. tongue load not to exceed 800 lbs. with Class IV trailer.

(d) Recommended for high ambient temperature.

(e) Auxiliary Transmission Oil Cooler (external) Std. w/460 engine. Recommended with Classes III & IV.

(f) Super Cooling Package.

(g) HD Trailer Towing Package recommended for towing trailers having more than 25 square feet frontal area.

F-350 Super Camper Special Ranger XLT with optional protection group, radio and western-type mirrors towing a fifth-wheel trailer



TRAILER TOWING PACKAGES:

FORD
TORINO
T-BIRD
RANCHERO

Ford again offers you all the essential heavy-duty components to meet your trailer-towing needs, in one convenient, low-cost package. The specific package content varies with the weight and size of the trailer you plan to tow.

Trailer towing packages are available for Ford, Torino, Thunderbird and Ranchero as factory-installed options; however, they must be specified at the time you order your vehicle. A Ford car,

properly equipped, can tow trailers up to 7,000 pounds gross trailer weight with as much as 800 pounds of tongue weight.

Some optional equipment is required with the purchase of a trailer towing package. Ford Trailer towing packages include a trailer towing plaque and all or a portion of the following equipment. See listings with each vehicle for specific equipment items included.

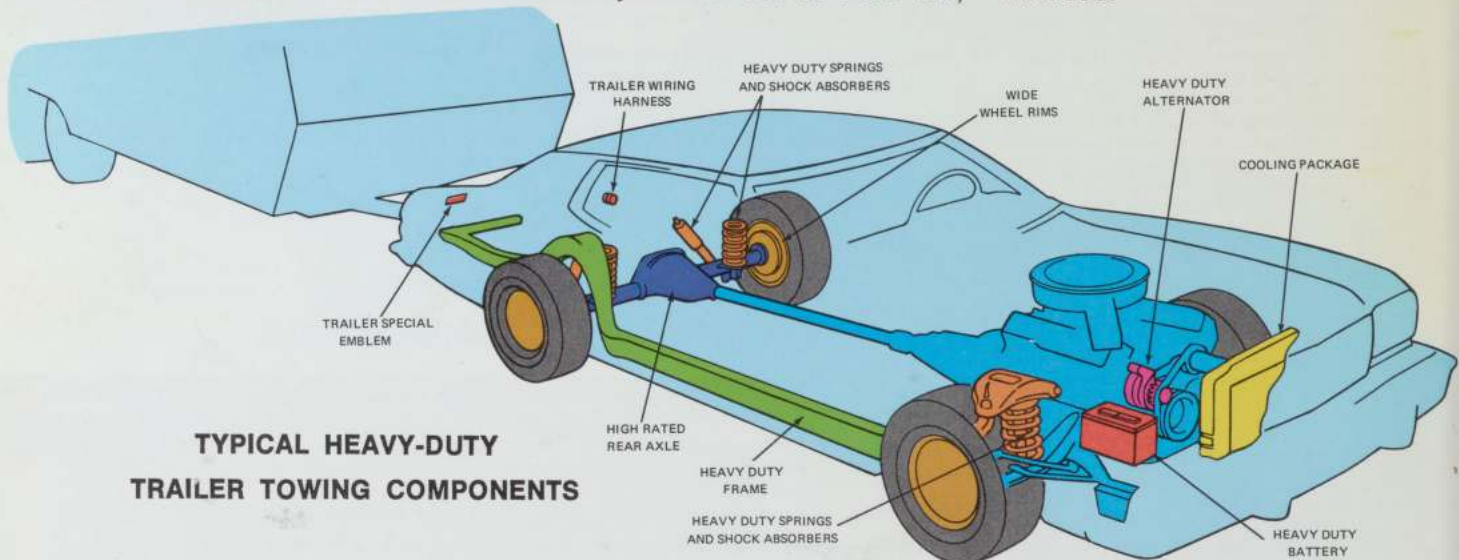

TYPICAL HEAVY-DUTY TRAILER TOWING COMPONENTS

Cooling Package

A heavy-duty radiator with large surface area provides more efficient engine cooling. It helps dissipate the extra heat developed by the engine due to air resistance and pulling the trailer up grades. A coolant recovery system is included in Class III packages.

Heavy-Duty Suspension

Trailers transmit extra loads through the hitch to the car's rear

suspension, and where weight distributing hitches are utilized, to the front suspension as well. To support these additional loads along with the normal loads imposed by the car, stiffer springs and heavy-duty shock absorbers are included in some towing packages.

Heavy-Duty Frame

A reinforced frame is part of the Ford and Torino Class III towing packages except for Torino station wagons (on which a heavy duty frame is standard). The heavy duty frame aids in distributing hitch loads to the car's front axle and wheels when a weight distributing hitch is used.

Wide-Rim Wheels

On standard-size Fords wider wheel rims are included to improve resistance to the side sway of loads exerted by larger trailers. These 6½-inch-wide wheels are standard on all standard-size Ford station wagons.

Rear Axle

Special higher ratio axles are included in selected towing packages to increase pulling power and reduce engine loads.

Heavy-Duty Electrical Components

Trailer towing places extra demands on your car's electrical system because of items such as trailer lights and electric brakes. A larger alternator and battery are included in Ford trailer towing packages to assure adequate electrical power and quick recovery for both car and trailer batteries.

Trailer Wiring Harness

A seven wire harness running to the rear of the car lets you tie into the electrical system to provide power to your trailer. An additional wire terminates under the dash to provide easy installation of a controller for electric trailer brakes. Each connector plug lead is fused and identified by color and a tag to identify specific electrical circuits.

22



Trailer camping—1930's.

TOW VEHICLE, TRAILER AND HITCH

The tow vehicle must have sufficient power and be equipped with the recommended options and accessories that will allow you to safely pull your trailer over all types of terrain, in all kinds of weather.

equipped to meet your trailering needs, Ford has developed Trailer Towing Packages for most Ford cars and trucks, which contain the recommended optional equipment for each vehicle. (The equipment contained in the packages is shown on pages 20, 21 and 22 of this brochure.)

THEY MUST BE MATCHED FOR MAXIMUM SAFETY AND TROUBLE-FREE TRAILERING

To insure that your tow vehicle is

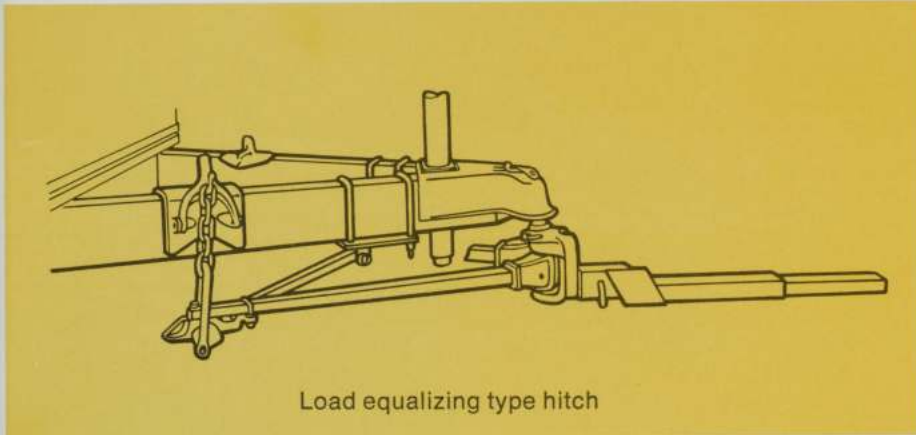

Load equalizing type hitch

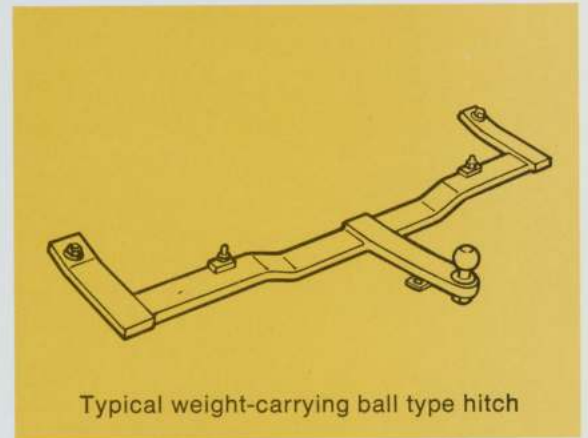

Typical weight-carrying ball type hitch

Weight: Important for towing safety

Weight is especially important in towing—particularly trailer weight. Factors to take into consideration with regard to trailer weight are discussed in detail on page 31.

Select the proper hitch!

Two ball type hitches are available. First, for lightweight trailer applications, there's the weight-carrying ball. It bolts to the rear of the tow vehicle and accepts the full weight of the trailer tongue. It's used for trailers with GTW (Gross Trailer Weight) of 2,000 pounds or less, with no more than 200 pounds of tongue load.

Hitches which clamp to the bumper are limited to rental multi-clamping types, and they should be located at the bumper mounting brackets.*

*Clamp-on bumper hitches are not recommended for Pinto or Mustang II.

The second ball type of hitch is the load-distributing or "equalizer" hitch. This hitch is recommended for trailers weighing more than 2,000 pounds fully loaded.

The load-distributing hitch transfers the tongue weight to the front and rear axles of the tow vehicle, and to the axle, or axles, of the trailer... through two spring bars. (Ideally, between 10 and 15% of

the gross trailer weight should be on the hitch ball.)

An anti-sway device, either built into the hitch or installed separately, is recommended for trailers weighing more than 3,500 pounds.

Also available for heavy-towing applications is a **hitch receiver**, which accommodates the standard 2-inch-square shank of most load-distributing hitches. (Ford offers a hitch receiver as an option on the standard-size Ford car.)

Ford does not recommend hitches which attach to the rear axle of the tow vehicle, as this may cause damage to the power train. (No single-point, clamp-on hitch should be used on any Ford vehicle.)

Other trailering equipment essential to safety

Trailer brakes are required on many trailers weighing over 1000 lbs.—check your state's requirements. Consult the manufacturer for the recommended installation, adjustment and operation of the various brake systems.

Note: Ford Motor Company does not recommend trailer braking systems that have a direct hydraulic brake fluid connection with the towing vehicle's braking system. Any trailer brake control system utilizing a connection to the towing vehicle hydraulic fluid system may increase the towing vehicle stopping distance.

The 5th Wheel Hitch.

There are two basic types of fifth wheel hitches, which are used for recreational vehicle applications. These are the Conventional type in which the fifth wheel hitch assembly is mounted in the bed of the pickup and the inverted type in which the kingpin is mounted flush with the pickup box.

Note: The installation of a fifth wheel trailer hitch is the responsibility of independent manufacturers.

Safety Chains

Safety chains and a breakaway switch to actuate the trailer's brakes are important if the coupling unit or hitch ball should fail. Chains should be crossed under the trailer tongue to prevent it from dropping to the road surface in case of failure. Chains should be loose enough to allow for turning. The breakaway switch should be mounted on the trailer's "A" frame and connected to the tow vehicle's frame so that it will only activate if the trailer and vehicle separate.

FORD... THE QUIET WAY TO GO CAMPING



Ford Country Squire with optional vinyl roof, white sidewall tires, deluxe luggage rack, convenience group, deluxe wheel covers, deluxe bumper group and dealer installed trailer towing mirrors

The closer you look, the better Ford looks . . . because of designed-in quality . . . extra craftsmanship and attention to detail. A car designed and built for your traveling comfort, to keep you relaxed and at ease during the longest trip. A rugged frame isolated from the body by cushioning rubber mounts helps shield you from bothersome road vibrations.

And Ford offers America's most popular full-size station wagons, including the luxurious Country Squire. Wagons that offer you Ford's versatile 3-way Doorgate . . .

ample room for your family's camping gear, a wide variety of interior trim selections and the choice of a dual facing rear seat option to let you carry extra passengers.

You can choose from 14 Ford models. All can tow up to 2,000 pounds without special trailer towing equipment, and with a Class III Trailer Towing Package your Ford can tow up to 7,000 pounds.



LTD Wagon with optional vinyl roof, deluxe luggage rack, deluxe bumper group, full wheel covers and white sidewall tires

24

TRAILER TOWING RECOMMENDATIONS—FORD

MINIMUM REQUIRED EQUIPMENT	CLASS I (Light) Up to 2000 lbs. loaded trailer weight	CLASS II (Medium) 2000-3500 lbs. loaded trailer weight	CLASS III (Heavy) 3500-7000 lbs. loaded trailer weight
Maximum Tongue Load (lbs.)	200	500	800
Trailer Hitch Type	Non-Equalizing	Load-Equalizing	Load-Equalizing
Engine	351-2V-STD	400-2V (min.) 460-4V (recommended)	400-2V (min.) 460-4V (recommended)
Transmission	Cruise-O-Matic—STD	Cruise-O-Matic—STD	Cruise-O-Matic—STD
Steering	Power—STD	Power—STD	Power—STD
Brakes	Power Disc—STD	Power Disc—STD	Power Disc—STD
Rear Axle Ratio	2.75:1—STD	2.75:1—STD	3.25:1 (a)
Tires	STD FOR ENGINE	J78 x 15 (b); LR78 x 15 (c)	J78 x 15 (b); LR78 x 15 (c)
Trailer Towing Package	Class I (recommended)	Class II (Medium)	Class III (Heavy)

(a) Included in Class III Trailer Towing Package

(b) Sedans (c) Wagons

CLASS I PACKAGE

- Wiring Harness
- Non-Equalizing Hitch
- Trailer Towing Plaque (bumper mounted)

CLASS II PACKAGE

- Heavy-Duty Suspension
- Cooling Package
- Wiring Harness
- Trailer Towing Plaque (bumper mounted)

CLASS III PACKAGE

- Heavy-Duty Suspension
- Heavy-Duty Battery
- Heavy-Duty Alternator
- Heavy-Duty Frame
- Cooling Package
- Wiring Harness
- 6½" Wheel Rims (STD on wagons)
- 3.25:1 Axle Ratio
- Trailer Towing Plaque (bumper mounted)

TOWING WITH TORINO... AMERICA'S FAVORITE MID-SIZE CAR



Gran Torino, Brougham 4-door pillared Hardtop with optional vinyl roof, deluxe wheel covers, white sidewall tires, deluxe bumper group and dealer installed trailer towing mirrors.

Torino, combining comfort and convenience with the easy handling and maneuverability of a mid-size car, can be equipped for towing trailers up to 6,000 pounds. Torino—the ideal mid-size car for trailer-towing—features a wide-track and full-coil 4-link rear suspension design that helps provide directional stability and sturdy, solid roadability. Trailer-towing with Torino becomes a driving pleasure thanks to its strong body/frame design and all-around sound insulation that helps provide a surprisingly quiet ride in a mid-size car.



Ranchero 500 with optional bumper protection group, whitewall tires and hub caps with trim rings.

VERSATILE RANCHERO...THE PICKUP CAR

Ranchero combines many of the features you would expect to find in a passenger car with the toughness and load-carrying ability of a pickup. Carry what you will in Ranchero—motorcycles, small boats or recreational gear. Hitch your trailer to Ranchero—it can tow up to 6,000 pounds with the equipment recommended below.

TRAILER TOWING RECOMMENDATIONS—TORINO/RANCHERO

MINIMUM REQUIRED EQUIPMENT	CLASS I (Light) Up to 2000 lb. loaded trailer weight.	CLASS II (Medium) 2000-3500 lb. loaded trailer weight.	CLASS III (Heavy) 3500-6000 lb. loaded trailer weight.
Maximum Tongue Load	200	500	700
Trailer Hitch Type	Non-Equalizing	Load-Equalizing	Load-Equalizing
Engine	302 2V (N.A. in Calif.)	351 2V (min.) 400 2V (recommended)	400 2V (min.) 460 4V (recommended)
Transmission	Cruise-O-Matic	Cruise-O-Matic	Cruise-O-Matic
Steering	Manual—STD	Power	Power
Brakes	Power Disc	Power Disc	Power Disc
Rear Axle Ratio	3.00:1 Ranchero—STD 2.79:1 Torino—STD (a)	3.25:1 (b)	3.25:1 (b)
Tires	STD for engine	STD for engine	H78—14 or equivalent
Trailer Towing Package	Not Required	Class II (Medium)	Class III (Heavy)

(a) 3.00:1 recommended for towing trailers with more than 25 sq. ft. frontal area.

(b) Included in Class II and III Trailer Towing package.

CLASS II PACKAGE

- Heavy-Duty Suspension
- Cooling Package
- Wiring Harness
- 3.25:1 Axle Ratio
- Trailer Towing Plaque (bumper mounted)

CLASS III PACKAGE

- Heavy-Duty Suspension
- Heavy-Duty Alternator
- 3.25:1 Axle Ratio
- Cooling Package
- Wiring Harness
- Heavy-Duty Frame (Std. Ranchero and Sta. Wagons)
- Trailer Towing Plaque (bumper mounted)

THUNDERBIRD

... LETS YOU TRAVEL IN UNCOMPROMISED LUXURY

Thunderbird is even more luxurious . . . more elegant . . . for '74. It combines uncompromised luxury and innovative engineering to establish its own standard of what a personal luxury car should be.

The suspension system has been refined and computer-tuned to the standard steel-belted radial-ply tires, for an extraordinarily smooth ride.

For your driving pleasure and added enjoyment, Thunderbird comes equipped with these features as standard equipment:

- 460 V-8 engine • Selectaire Conditioner • Tinted glass • Select-Shift Cruise-O-Matic Transmission
- Power Front disc brakes • Power Steering • Vinyl Roof • Opera

window • Spare tire lock • Power windows • Individually-adjustable front seats . . . and much more.

In addition, you can personalize your Thunderbird by choosing any of the many available options, including a sliding moon roof and power mini-vent windows.

And with all that luxury, you get premium trailering performance, with the ability to tow trailers weighing up to 6,000 lbs. gross weight, when your Thunderbird is equipped with a Class III package.



Thunderbird 2-Door Hardtop with optional exterior decor group, deluxe bumper group and deluxe wheel covers

TRAILER TOWING RECOMMENDATIONS—THUNDERBIRD

MINIMUM REQUIRED EQUIPMENT	CLASS I (Light) Up to 2000 lb. loaded trailer weight	CLASS II (Medium) 2000-3500 lb. loaded trailer weight	CLASS III (Heavy) 3500-6000 lb. loaded trailer weight
Maximum Tongue Load (lbs.)	200	500	700
Trailer Hitch Type	Non-Equalizing	Load-Equalizing	Load-Equalizing
Engine	460-4V-STD	460-4V-STD	460-4V-STD
Transmission	Cruise-O-Matic—STD	Cruise-O-Matic—STD	Cruise-O-Matic—STD
Steering	Power—STD	Power—STD	Power—STD
Brakes	Power—STD	Power—STD	Power—STD
Rear Axle Ratio	2.75:1 STD (a)	3.25:1 (b)	3.25:1 (b)
Tires	STANDARD STEEL-BELTED RADIAL PLY TIRES		
Trailer Towing Package	Not Required	Class III	Class III

(a) 3.25:1 recommended for towing trailers with more than 25 sq. ft. frontal area

(b) Standard with Class III Towing Package

CLASS III PACKAGE

- Heavy-Duty Suspension
- Cooling Package
- 3.25:1 Axle Ratio
- Heavy-Duty Alternator
- Wiring Harness
- Trailer Towing Plaque (bumper mounted)

FORD SMALL CARS...

DESIGNED WITH CAMPERS IN MIND



Maverick 4-Door Sedan with Luxury Decor Option
Pinto Runabout with optional sun roof and sports accent group
Mustang II Ghia

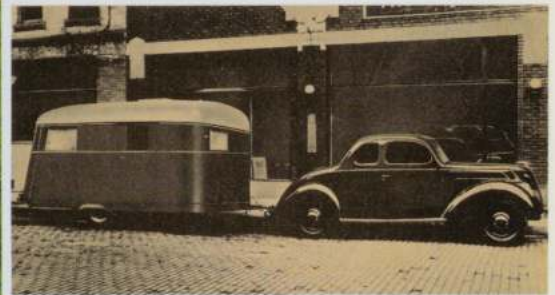

Early version of a travel trailer, pulled by a 1937 Ford Coupe.

PINTO . . . Dependable, economical way to go

Pinto, the thrifty one — is a basic, dependable little car that can put more pleasure into your recreation travel. Pinto can pull trailers weighing up to 800 pounds with such recommended equipment as the standard 2000cc engine and optional Cruise-O-Matic Transmission. You'll find the versatile little Pinto a pleasure to travel in, with features like rack-and-pinion steering, wide-stance stability, and a durable, economical 4-cylinder engine. And Pinto offers you a wide selection of comfort and convenience options to choose from . . . to add to your traveling enjoyment.

Match a MAVERICK to Your Recreation Needs

If you're looking for economical transportation without sacrificing convenience or comfort, consider the family-size Maverick. You'll get enough pulling power to tow trailers weighing up to 2,000 pounds, when equipped with the standard 200 cubic-inch 6-cylinder engine and optional automatic transmission. Maverick options also include a responsive, yet economical 302 V-8 and power steering. And you can add the Luxury Decor Option, for the kind of luxury and comfort that you would expect in a car costing thousands of dollars more.

MUSTANG II. A New Class of Small Car . . .

Make it a part of your vacation plans

Mustang II . . . the forerunner of a brand new breed of small cars . . . with a level of jewel-like quality you would never expect in a car of its size. Mustang II has an unusually smooth ride thanks to such features as a special rear Iso-Clamp Suspension, and an isolated sub-frame up front that helps reduce road shocks. For responsive performance and handling . . . there's a 2.3 liter overhead cam engine and precise rack-and-pinion steering—standard.

27

TOWING RECOMMENDATIONS—MUSTANG II, MAVERICK, PINTO

CLASS I—LIGHT WEIGHT TRAILERS ONLY			
MINIMUM RECOMMENDED EQUIPMENT	MUSTANG II	MAVERICK	PINTO (Except Station Wagons)
Maximum Tongue Load (lbs.)	100	200	100
Maximum Trailer Weight (lbs.)	1000	2000	800
Maximum Frontal Area (sq. ft.)		25	
Trailer Hitch Type (a)		Non-Equalizing	
Engine	2800 cc	200-1V—STD	2000 cc—STD
Transmission		STD	
Steering		Cruise-O-Matic	
Brakes	Power Front Disc	STD	Manual Front Disc—STD
Rear Axle Ratio	3.55:1—STD	2.79:1—STD	3.40:1—STD
Tires	B78-13—STD	6.45-14—STD	6.00-13—STD
Trailer Towing Package	—	—	Class I

(a) Bumper-mounted hitches not permitted

CLASS I PACKAGE (Pinto Only)

- Cooling Package

FORD OPTIONS LET YOU TAILOR TO BETTER MEET YOUR RECREATION NEEDS



PICKUP ENGINE AVAILABILITY

Engine	Bore and Stroke (in.)	Model
240 cu. in. Six(a)	4.0 x 3.19	Std. F-100
300 cu. in. Six(d)	4.0 x 3.98	Std. F-250, F-350 Opt. F-100 4 x 2(b)
302 cu. in. V-8	4.0 x 3.0	Opt. F-100 4 x 2
360 cu. in. V-8(c)	4.05 x 3.50	Std. F-350 Styleside and SCS, Opt. F-100 4 x 2(b) and all others
390 cu. in. V-8(a)	4.05 x 3.78	Opt. All 4 x 2's
460 cu. in. V-8(a)	4.36 x 3.85	Opt. 4 x 2's

(a) N.A. in Calif. in F-100 4 x 2 and 4 x 4.
 (b) Includes Calif. emissions package.
 (c) Required F-100 4 x 4 Calif.
 (d) Required F-100 4 x 2 Calif.

Pickup

1 Big 22.5-gallon auxiliary fuel tank—(20.2 gal. in F-100 pickup). Fills on the same side of the truck as the main tank.

2 Ford's camper body tie-down system—Frame-anchored to secure the camper body directly to the vehicle frame. Tie-downs are easily adjustable and removable.

3 Sliding rear cab window—Lockable, with weather-proof construction. Outer molding designed to accept a weather seal boot between cab and camper.

4 Air conditioner—For maximum traveling comfort. Smartly styled, integral unit.

5 Auxiliary 12-volt 70 amp-hr battery—Powers the camper's electrical system. Both the standard and auxiliary batteries recharge while you drive.

6 Slide-out spare tire carrier—Makes it easy to pull spare tire from its under-frame location.

(Bodyside spare tire carrier standard on F-350 Super Camper Special.)

7 Ford Engine Families—Full range of engines available to meet all driving needs.

Other options to consider:

- Special rear axle ratios, for extra-rugged camper duty
- Power Steering
- Heavy-duty shock absorbers
- SelectShift Cruise-O-Matic transmission
- AM/FM stereo radio
- Super Cooling Package for added engine efficiency in hilly terrain and hot weather.

Bronco

- Skid plates for standard fuel tank and transfer case.
- High flotation tires for extra traction on sand and soft surface (L-78 x 15B).
- Swing-away spare tire carrier,

- for more luggage area.
- Auxiliary fuel tank with skid plate.
- Extra cooling radiator (302 V-8 only).
- Traction-Lok rear axle.
- Power steering.
- Cruise-O-Matic transmission.

Ranchero

- Air conditioner with automatic temperature control.
- Heavy-duty suspension.
- Cruise-O-Matic transmission.
- Power steering.
- Power front disc brakes.
- Finger Tip Speed Control.

Club Wagon and Econoline Vans

- 302 V-8 engine.
- Air conditioner.
- Power-steering.
- Cruise-O-Matic transmission.
- Western-type rear view mirrors.
- Power brakes.

YOUR TRUCK OR CAR...

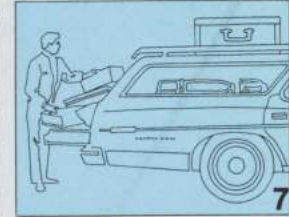
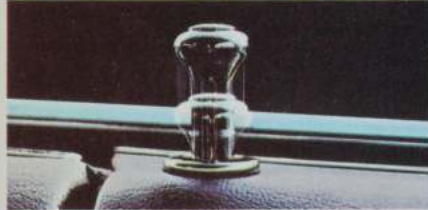
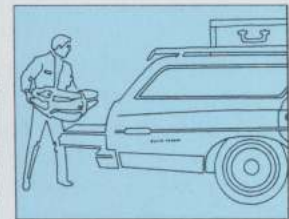
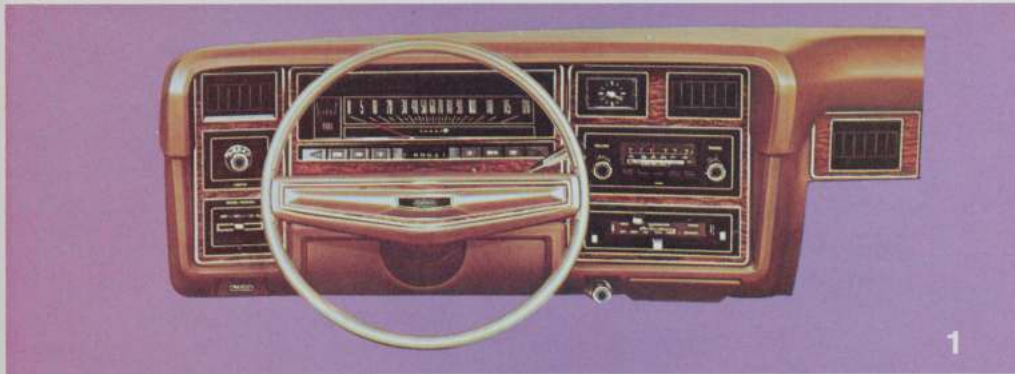

Passenger car options:

1 Selectaire Conditioner with automatic temperature control, automatically controls the temperature you select. (Ford, Thunderbird and Torino.)

2 AM/FM radio with 8-track stereo tape deck—Music as you like it, even in the most remote areas. (Ford, Thunderbird, Torino and Mustang II.)

3 Load-distributing hitch receiver—Includes a square tube sleeve to accommodate hitch head. (Ford.)

4 Power or Manual Mini-Vent Front Windows for added ventilation, (Ford 4-door, Thunderbird). **Power Door Locks** add convenience and security. (Ford, Torino, Thunderbird.)

5 Quick Defrost Windshield/Rear Window. Heat conducting Gold film, laminated in glass

quickly helps melt snow and ice. (Thunderbird.)

6 Electric rear window defroster, for good rear visibility. (Available on most models.)

7 Automatic load adjuster—Maintains car's level attitude, whatever the load. Available with Class I and Class II trailer towing packages.

8 Steel-belted radial tires—For extra performance and tire economy. (All cars; std. on Thunderbird.)

9 Recreation table—Available on standard-size Ford wagons with Dual Facing Rear Seats.)

• **Luggage rack**—Ford and Torino wagons; all Pintos

• **Automatic speed control**—Ford and Thunderbird

• **Sure Track brake control system**—Thunderbird

• **Interval windshield wipers**—Ford, Torino, Thunderbird

• **Electric trunk lid release**—Thunderbird and Ford

Accessories for camping by car or truck:

- Battery booster cables
- Fire extinguisher
- Reflector flare kit
- Trailer towing mirrors
- Trailer wiring harness (for cars not equipped with towing packages)

Other options to consider:

- **Tilt steering wheel**—Ford, Torino, Mustang II, Thunderbird
- **Tinted glass**—recommended with air conditioning, all cars

See your Ford dealer for a complete list of options and accessories for all Ford car and truck lines

TIPS FOR SAFE, TROUBLE-FREE TRIPS

LOAD YOUR VEHICLE: WITH WEIGHT DISTRIBUTION IN MIND

The distribution of gear, clothing and food within your camper or trailer affects vehicle handling. An improperly loaded camper or trailer may adversely affect your vehicle's handling and performance.

Follow these suggestions:

- **Carry only essential items.** Consider leaving those items at home which can be purchased as you travel—food, for instance. Before a trip, check your equipment and eliminate those items you never seem to use.

- **Place heavy articles,** canned goods, tools, etc., as low to the floor as possible. This helps keep the center of gravity low so your rig isn't top heavy, makes it more stable—especially on curves.

- **Balance the load from side to side.** Distribute heavy items so that one side doesn't carry more weight than the other.

- **Place lightweight items,** bedding, clothing, etc., in high cabinets or in the cab-over section of your pickup camper.

- **Secure all doors and drawers** against opening in route. Nothing should be left loose in the living area, to cause damage or changes in weight distribution.

- **Keep emergency items,** flashlights, flares, first aid kits, etc., in a place where they can be reached quickly. Mark their container for easy identification. (Make sure that all members of your family know where these items are and how to operate them.)

"Pre-flight check" your vehicle before leaving your driveway

One sure way to enjoy a safe vacation is to develop your own trip check list so you can "pre-flight check" your recreational vehicle in much the same way that a pilot goes over his aircraft before take off. Here are some of the things you should check-out before leaving:

- Check tires for proper inflation pressure (cold) and for possible signs of excessive wear.
- Check the wheel lug nuts for tightness.
- Check contents of propane tanks; make sure fittings are without leaks.
- Check the valves on the propane gas bottles to assure they are turned off for travel. (Make sure there are no open flames or pilot lights burning while traveling.)
- Check all running, brake and turn signal lights for proper operation. If you have a trailer, do this after you hitch up since the electrical connector acts as a ground between the two vehicles.

- Hitch the trailer to the car properly. This is essential for good towing.

It is recommended that you have the hitch installation performed by a factory-trained installer familiar with your make hitch.

- Connect the safety chains, break-away switch and the electrical connector. Don't forget to crank up the front jackscrew and stow the jack wheel in a convenient location.

- As you start your trip, check to

assure your trailer brakes are functioning and adjust them if necessary.

- If you have a friction type anti-sway device, do not lubricate friction surfaces.
- Check to see that you have essential equipment on board. Axle jack, $\frac{7}{8}$ " wrench for LPG tank . . . power cord, plastic water hose, pail . . . drain hoses for sink and toilet. Also, spare gas lamp mantles and spare bulbs for outside lights.

Trailer weight considerations:

One good way to assure full enjoyment of your trailering trips is to eliminate loading problems before they start. Here are some tips on doing just that!

- Make sure that you keep the total weight of your unit—towing vehicle, trailer and equipment—within legal weight limits and the tow vehicle manufacturer's specifications. There are **two** weight factors to consider:

- (1) **Gross trailer weight.** Weight of empty trailer with all trailer options plus whatever payload the trailer will be carrying . . . such as food, water, clothing, propane and extra batteries. (Everything not included in the manufacturer's dry trailer weight.)

- (2) **Tongue weight.** The weight that pushes down on the hitch ball—this is the weight that your trailer adds to the rear of your vehicle.

It is essential that the Gross Trailer Weight and Tongue Weight do not exceed the rated capabilities of the towing vehicle.

HOW TO FIGURE THE GROSS TRAILER WEIGHT/TONGUE LOAD CAPACITY

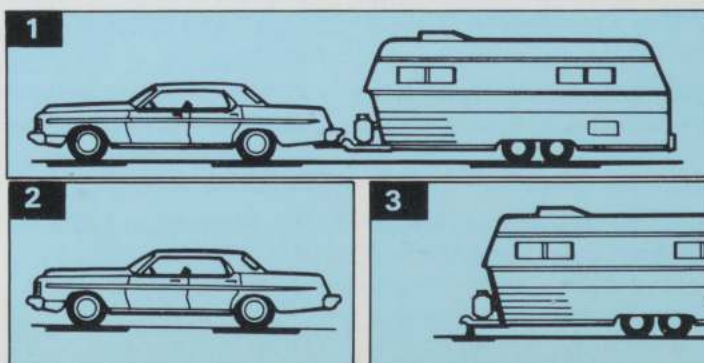

(1) To determine Gross Trailer Weight, weigh both the towing vehicle and trailer. (2) Then weigh the towing vehicle. The difference is Gross Trailer Weight. (3) To determine Tongue Weight, disconnect the trailer and place the tongue only on the scale with the coupler at hitch ball height. If the tongue load exceeds 15% of the gross trailer weight, shift extra camping gear and equipment etc., in trailer rearward to the degree necessary to achieve recommended tongue load for your trailer class. If less than 10%, shift load forward.

The purpose of this page is to help you choose the proper camper for your truck, or if you already have a camper—to make sure you have chosen the correct truck for that camper.

Weight watching is very important, as overloaded trucks are unsafe and can result in costly vehicle and equipment breakdowns.

Weight watching involves these important factors:

- Your pickup's cargo carrying capacity (Cargo Weight Rating)
- Your camper's body weight with supply tanks filled to design capacity.
- The weight of everything else you take with you, including yourself and passengers.
- The manner in which you distribute the total load on your pickup.

Remember, vehicle and equipment manufacturers cannot be blamed for *Overloading*, once it is in the hands of the owner. So, carefully consider these important weight factors before making your equipment purchase:

Know your pickup's cargo carrying capacity!

Understanding your pickup's cargo carrying capacity requires a basic knowledge of the following factors:

Gross Vehicle Weight Rating is the maximum allowable loaded weight of the vehicle. It includes the pickup itself, camper body, options, recreational equipment, supplies and people. The maximum loaded weight of your vehicle should not exceed the GVWR specified on the safety certification label located on the door frame on the driver's side of the vehicle.

Gross Axle Weight Rating is the maximum allowable loaded weight on each axle system. The load on each axle system should not exceed the GAWR which is specified on the safety certification label. Additionally, the total load on both axle systems must not exceed the GVWR of the vehicle.

The Total Unloaded Weight of your vehicle is the weight as it is

WEIGHT FACTORS TO CONSIDER WHEN MATCHING YOUR PICKUP AND CAMPER

KNOW YOUR TRUCK'S WEIGHT CAPACITY

delivered to you with no cargo or occupants but including all fluids (full gasoline tanks, radiator, etc.). This unloaded weight and its distribution between each axle system is dependent on the option content of your particular vehicle.

Since the cargo carrying capacity of your pickup depends upon the above factors and is a unique value of your particular vehicle, it is necessary that you consult the Truck Camper Loading Consumer Information available at your Ford dealer. This information will allow determination of the cargo carrying capacity (cargo weight rating) and proper load distribution (center of gravity zone) for your vehicle.

Choose a camper within your pickup's capacity!

Once you have determined your pickup's cargo weight rating and allowable center of gravity zone, make sure the camper you are considering is within that capacity.

The weight of the camper body, camper options, supplies, equipment, etc. must never exceed the cargo weight rating you have determined from the Truck Camper Loading Consumer Information available at your Ford dealer. Base camper weights and individual option weights are provided with campers manufactured after January 1, 1973. Additionally, center of gravity information to match your camper to your truck is provided with campers manufactured after October 1, 1973.

After you have selected your camper, are "packed up" and ready to roll, you should assure yourself that your pickup's load

capacities have not been exceeded; people, equipment and supplies may have added more weight than you estimated. Drive to a scale and weigh the front and rear wheels separately to determine axle system loads. Individual axle system loads should not exceed their respective GAWR's. The total of the axle loads should not exceed the GVWR. If any of these weight ratings are exceeded, move or remove items to bring all weights below the specified ratings. Trucking companies, sand/gravel companies and other commercial facilities have scales that can be used for weighing your vehicle.

Plan for maximum fuel economy.

Ford trucks—and cars—provide a broad selection of engines and power train components, so that you can get the right combination to assure the best possible performance and economy. In addition, to maximize your fuel economy, make sure your engine is well-tuned before you start out on a trip. And check to see that your vehicle's tires are properly inflated (on Ford trucks, use the tire pressure recommended for the GVW rating tire size, shown in the Owner's Manual). Once on the road, avoid jack-rabbit starts and drive at moderate speeds.

When You Load Remember...

1

THE MAXIMUM WEIGHT OF YOUR RIG (GVWR) INCL.

- PICKUP (EMPTY)
- PICKUP OPTIONS
- CAMPER BODY
- EQUIP. & SUPPLIES
- PASSENGERS

• SHOULD NOT EXCEED YOUR PICKUP'S GVWR AS SHOWN ON THE SAFETY CERTIFICATION LABEL

2

THE MAXIMUM WEIGHT ON EACH AXLE (GAWR)

• SHOULD NOT EXCEED YOUR PICKUP'S FRONT AND REAR GAWR'S AS SHOWN ON SAFETY CERTIFICATION LABEL

NOTE: Descriptions and specifications contained in this catalog were in effect at the time this publication was approved for printing, and are subject to change without notice or liability, therefore, Ford Marketing Corporation reserves the right to change or discontinue options or accessories at any time. Availability may be subject to Environmental Protection Agency certification.

1974 FORD RECREATION VEHICLES... BETTER IDEAS FOR THE OUTDOORS!

