

# '88 FORD ECONOLINE CHASSIS



# '82 Ford Econoline Chassis

More Ford Econoline Vans are on the road today than any other make. Again, in 1981, they're America's best sellers.\* And Ford Econoline Cutaway models (RV and commercial versions) and Commercial Stripped Chassis models are Econolines offered without bodies so you can install the body of your choice. Also, there is a complete line of Parcel Delivery Vans available.

Econoline Chassis models, like all Ford Trucks, are built tough and ready for the job that has to be done. Econoline Chassis offers the flexibility to suit a variety of job applications.

\*Based on cumulative registrations as of May, 1981.

## **Econoline Commercial Cutaway Model**

This popular model offers the front-end sheetmetal and front compartment of an Econoline Van. It features out-front service center and bolt-on front fenders for easy servicing and repairs. The flat-face B-pillar design allows a tight seal between the driver's compartment and rear body.

## **Econoline Commercial Stripped Chassis Model**

The tough, efficient Econoline Commercial Chassis comes without a body, driver's compartment or front-end sheetmetal. It's ready for full conversion by a custom body manufacturer. Available with 138", 158" and 176" wheelbases.

## **Econoline Parcel Delivery Vans**

The driver's compartment is pure Econoline...with a tough van body, 12 or 14 feet long.

## **Econoline RV Cutaway Model**

Econoline can be outfitted for fun, too. The RV Cutaway model is available with RV Camper Packages for popular mini motorhome conversions.

## **Instrument Panel**

Easy-to-read instruments highlight the full-width instrument panel. It's included with the various Cutaway models and the Parcel Delivery Van.

## **Driver's Seat**

A full-foam contoured bucket seat is standard for the driver on RV or Commercial Cutaway models and Parcel Delivery Vans. An optional passenger seat is available.



# Here are the reasons Ford Econoline Vans are so popular.

## **Twin-I-Beam Front Suspension**

Two steel I-beam axles comprise Ford's independent front suspension system. Each front wheel employs an axle and big coil spring to step over bumps independently. Ford toughness underneath makes for smooth going behind the wheel.

## **Out-Front Design**

Econoline's interior roominess owes much to the forward, out-of-the-way location of the engine and front axle. There's plenty of move-around room to step across to the passenger side, and to enter and leave by any door.

## **Front Service Center**

The engine-forward design, along with Econoline's mini-hood, offers another practical benefit. Many servicing operations can be performed out front—right under the hood—for convenient maintenance.

## **Rugged Body-On-Frame Construction**

Body-on-frame construction provides Econoline's solid foundation with deep, full-length siderails and five crossmembers. Rubber mounts, positioned at key points along the siderails, help keep harshness and vibration from the driver and cargo compartments.

## **High-Torque Six-Cylinder Engine**

In addition to outstanding fuel economy, the standard 4.9L (300) I-6 offers high-torque capability, especially appreciated when your Econoline is carrying a big load.



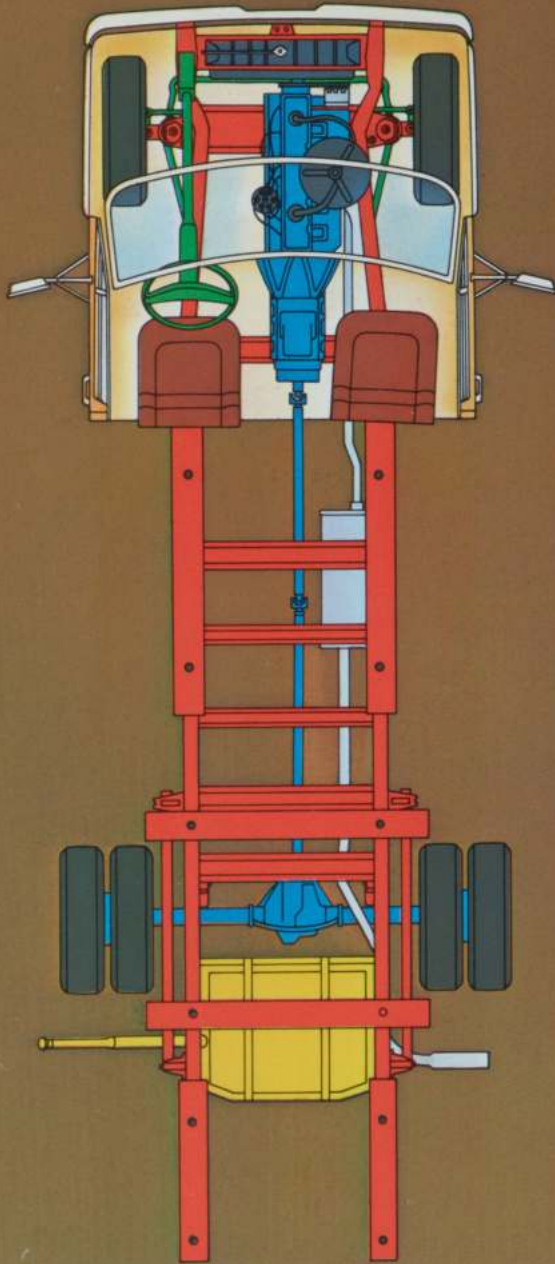

**Exclusive Twin-I-Beam front suspension.**

**Power front disc brakes.**

**Power steering.**

**Big choice of power teams. From the largest 6-cylinder van engine to the largest V-8 van engine (except Stripped Chassis).**

**Transmissions: 3-speed manual (RV Cutaway and PDV), 4-speed manual (Stripped Chassis), SelectShift automatic (Commercial Cutaway).**

**Tough ladder-type frame. Strategically placed rubber mounts with RV Cutaway.**

**Front and rear shock absorbers.**

## Econoline School Bus

The School Bus Body Builders Preparation Package is designed to meet N.E.A. standards, and is offered on E-350 Econoline Super Vans (Cargo and Window Vans). It includes 60 amp. alternator, HD 68 amp-hr. maintenance-free battery, banded front door main glass (tinted and laminated), courtesy light switches on all doors, rear door latch and lock, comfort ride suspension and brake modifications as required. Bus conversions can be completed by various manufacturers to meet your school's needs. A School Bus Body Builders Preparation Package is also available on Commercial Cutaway or Stripped Chassis models.

## Econoline Ambulance Package

The Ambulance Body Builders Preparation Package, available on E-350 Econoline Super Vans, includes: Comfort Ride Suspension Package, 4:10 to 1 Limited Slip rear axle (3.73 with 7.5L engine), Select-Shift automatic transmission, auxiliary transmission oil cooler (V-8 engines only), air conditioning (in instrument panel), tinted glass, auxiliary fuel tank, dual 68 amp-hr. batteries, adjustable passenger seat, ammeter and oil pressure gauges, fixed rear door glass, inside rear door latch and lock, 3700-lb. front springs and GAWR, front stabilizer bar, and spare tire. An Econoline RV Cutaway Ambulance Body Builders Preparation Package is also available.

## Parcel Delivery Van Options

Special options for Parcel Delivery Vans include: Cargo area light (rear of van body), partitions (solid or mesh with sliding door), interior steel rub rails, interior steel wall panels, rear cargo door with windows, roll-up rear cargo door (with or without windows) and under-frame spare tire carrier.

In addition, many of the Econoline Van options—air conditioning, tilt steering wheel, speed control, etc.—are available.

# Dimensions

## PDV

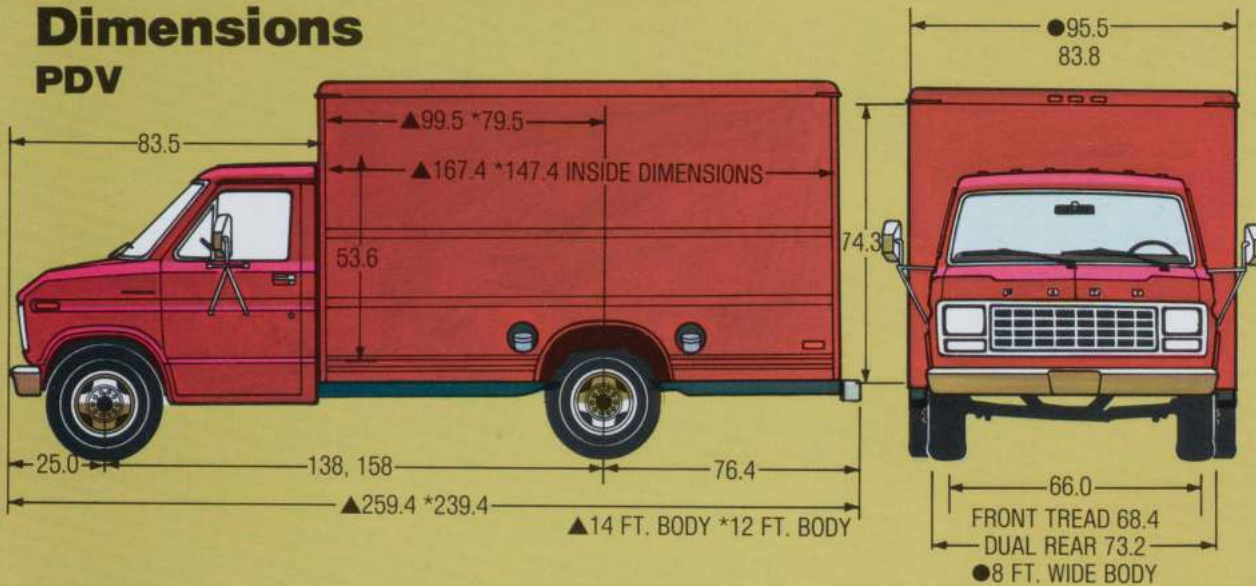

CARGO VOLUME (Max.)		
Series	WB	Rear Wheels
E-350	138	Single
	138	Dual
	158	Dual
Series	WB	PDV Body Size
E-350	138	12' x 7'
	138	12' x 8'
	158	14' x 8'
Series	WB	Cu. Ft. †
E-350	138	493
	138	566
	158	645

†Without partitions.  
Dimensions (in.) are for base model w/standard equipment.

# RV Cutaway, Commercial Cutaway, Commercial Stripped Chassis

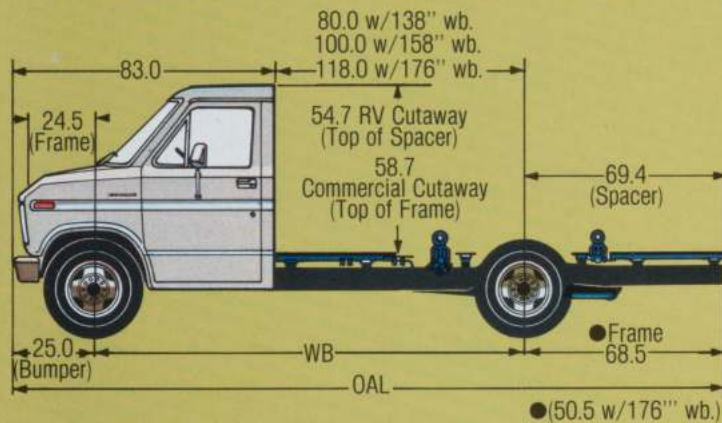

OAL	
WB	RV Cutaway
138	232.4
158	252.4
176	251.5
WB	Commercial Cutaway
138	231.5
158	251.5
176	251.5
WB	Stripped Chassis
138	231.1
158	251.1
176	251.1

# Specifications

	STRIPPED CHASSIS		STANDARD CUTAWAY	
	COMMERCIAL	RV	E-350	E-350
Series	E-350	E-350	E-350	E-350
Payload Pkg./Max GVWR: lb.	V/9,800	5/11,000	4/9,900†	4/9,900†
Axle, Front: Rating (lb.)	4,200	4,200	4,200	4,200
Axle, Rear (single): Rating (lb.)	6,340	6,340	6,340	6,340
Axle, Rear (duals): Rating (lb.)	7,400	7,400	7,400	7,400
Brakes: Power (disc/drum)	Std.	Std.	Std.	Std.
Clutch: Dia. (in.)	11	11	—	—
Electrical: Battery* (amp-hr.)	36 (310 CCA)	36 (310 CCA)	45 (380 CCA)	45 (380 CCA)
Optional Battery* (amp-hr.)	68, 82	68, 81	68, 81	68, 81
Alternator (amp.)	40	40	40	40
Optional Alternator (amp.)	60, 100	60, 100	60, 100	60, 100
Engine: Displacement	4.9L (300) I-6	4.9L (300) I-6	4.9L (300) I-6†	4.9L (300) I-6†
Optional	5.8L (351) V-8†	5.8L (351) V-8† 6.6L (400) V-8** 7.5L (460) V-8†	5.8L (351) V-8† 6.6L (400) V-8** 7.5L (460) V-8†	5.8L (351) V-8† 6.6L (400) V-8** 7.5L (460) V-8†
Shock Absorbers	F & R	F & R	F & R	F & R
Springs, Front: Combined Rating @ Ground (lb.) Optional	—	Computer Selected Heavy Duty	—	—
Rear: Combined Rating @ Ground (lb.) Optional	—	Vary by Payload/GVWR Pkg.	—	—
Power Steering	Std.	Std.	Std.	Std.
Transmission Optional	4-spd. SelectShift Auto.†	3-spd. SelectShift Auto.	SelectShift Auto.	—
Wheels: (Number) Type Rim Size	(4) 8-Hole 6.75 6.00 F & DR	(4) 8-Hole 6.75 6.00 F & DR	(4) 8-Hole 6.75 6.00 F & DR	(4) 8-Hole 6.75 6.00 F & DR
Tires	9.50 x 16.5E 7.50 x 16D F & DR	9.50 x 16.5E 8.00 x 16.5D F & DR	9.50 x 16.5E 8.00 x 16.5D F & DR	9.50 x 16.5E 8.00 x 16.5D F & DR

Optional—sizes to match GVWR requirements. Use adequate tires for loads and type of service. Consult your Ford Dealer.

RV=Recreation Vehicle \*All batteries except optional 81 amp-hr. are maintenance-free †N.A. in Calif. \*\*Calif. only ‡Higher GVWRs available through DSO

■ OAL dimensions are derived as follows: From bumper to end of frame spacer on RV Cutaway; from bumper to end of frame on Commercial Cutaway; from front of frame to end of frame on Commercial Stripped Chassis. Dimensions (in.) are for base model w/standard equipment.

# Econoline Cutaway Chassis Trim Content (excludes Stripped Chassis)

	Standard Trim	XL Trim
<b>EXTERIOR</b>		
Windshield molding	Bright	Bright
Hub caps	Argent (SRW only)	Bright (SRW only)
Bumpers	Argent (front only with RV/Commercial Cutaway)	Bright (front only)
Outside mirrors (bright)	PDV only	PDV only
Bright grille surround molding	—	Standard
<b>INTERIOR</b>		
Vinyl seat trim	Standard	Standard
Floor covering	Black insulated floor mat—rubber/vinyl front compartment—LH	Color-keyed carpeting (front only)
White hardboard front headliner	Standard	Standard
Color-keyed LH and RH roof rail garnish moldings	—	Standard
Color-keyed RH cowl side trim panel	—	Standard
Color-keyed belts	Standard	Standard
Instrument panel	Color-keyed pad with black inset panels	Color-keyed pad with woodtone inset panels and bright "XL" emblem on RH side
Steering wheel, black horn pad with woodtone surround	—	Standard
White padded sun visors	Standard	Standard
Color-keyed front door trim panels with woodtone inserts and map pockets	—	Standard
Cigarette lighter	—	Standard

# '82 Ford Econoline Chassis

## Ford-Paid Repair Programs after the Warranty Period

Sometimes Ford offers adjustment programs to pay all or part of the cost of certain repairs. These programs are intended to assist owners and are in addition to the warranty or to required recalls. Ask Ford or your dealer about such programs relating to your Ford or Lincoln-Mercury vehicle.

To get copies of any adjustment program for your vehicle or the vehicle of interest to you:

Call Ford toll-free at 1-800-241-3673. Alaska and Hawaii call 1-800-243-3711 and in Georgia call 1-800-282-0959.

Or write Ford at:

Ford Customer Information System  
Post Office Box 95427  
Atlanta, Georgia 30347.

We'll need your name and address; year, make, and model vehicle, as well as engine size; and whether you have a manual or automatic transmission.



## Replacement Parts

Be sure to specify genuine Ford-approved Motorcraft parts from your Ford Dealer.

...FOR SURE

## Technical Service Bulletins

All vehicles need repairs during their lifetime. Sometimes Ford issues Technical Service Bulletins (TSBs) and easy-to-read explanations describing unusual engine or transmission conditions which may lead to costly repairs, the recommended repairs, and new repair procedures. Often a repair now can prevent a more serious repair later. Ask Ford or your dealer for any such TSBs and explanations relating to your Ford or Lincoln-Mercury vehicle.

To get copies of these Technical Service Bulletins and explanations for your vehicle or the vehicle of interest to you:

Call Ford toll-free at 1-800-241-3673. Alaska and Hawaii call 1-800-243-3711 and in Georgia call 1-800-282-0959.

Or write Ford at:

Ford Customer Information System  
Post Office Box 95427  
Atlanta, Georgia 30347.

We'll need your name and address; year, make, and model vehicle, as well as engine size; and whether you have a manual or automatic transmission.

Specifications, descriptions and illustrative material contained herein were as accurate as known at the time this publication was approved for printing. Ford Division reserves the right to discontinue models or options at any time or change specifications and materials, equipment or design without notice and without incurring obligation. All options and accessories illustrated or referred to as optional or available are at extra cost. Some options are required in combination with other options. For the price of the model with the equipment you desire or verification of specifications contained herein, see your Ford Dealer.

Federal regulations such as those issued by the National Highway Traffic Safety Administration, the Environmental Protection Agency or the Federal Highway Administration or issued pursuant to the Occupational Safety and Health Act (OSHA), and/or state and local laws and regulations, may require additional equipment for the particular use you intend for the vehicle. It is the buyer's responsibility to determine the applicability of such laws and regulations to the buyer's intended use for the vehicle, and to arrange for the installation of required equipment. Your Ford Dealer has information about the availability of many items of equipment which can be ordered for the vehicle.

Many of the items shown on vehicles in this publication are available through retail organizations and establishments not connected with Ford Motor Company. Availability, price, quality and durability of these items rest solely with the respective manufacturers and their sales organizations, and Ford assumes no responsibility for their use.

# FORD TRUCKS

FORD DIVISION



Buy or lease a tough  
Ford Econoline —  
a great choice either way!

